

NOTE: WHERE THERE IS MORE THAN ONE JUMP WITHIN A BRANCHPOINT BOX, THE JUMPS ARE TO BE APPLIED IN ORDER FROM THE TOP.

G1. Now I'm going to ask you some questions about your current employment situation.

Are you working now, temporarily laid off, unemployed and looking for work, disabled and unable to work, retired, a homemaker, or what?

[IWER: DO NOT PROBE BUT CHOOSE ALL THAT APPLY]

1. WORKING NOW	2. UNEMPLOYED AND LOOKING FOR WORK	3. TEMPORARILY LAID OFF, ON SICK OR OTHER LEAVE	4. DISABLED	
5. RETIRED	6. HOMEMAKER	7. OTHER (SPECIFY) _____	8. DK	9. RF

G1a BRANCHPOINT: IF R DID NOT REPORT THAT IS UNEMPLOYED (G1 NOT 2), GO TO G1c BRANCHPOINT

G1a. In what month and year did you become unemployed?

[IWER: MONTHS ENTERED MUST BE BEFORE OR ON CURRENT IW MONTH, YEAR]

G1a. MONTH:

01. JAN	02. FEB	03. MAR	04. APR	05. MAY	06. JUN	07. JUL
08. AUG	09. SEP	10. OCT	11. NOV	12. DEC	98. DK	99. RF
_____	DK	RF				

G1b. YEAR

G1c BRANCHPOINT: IF R DID NOT REPORT THAT IS {TEMPORARILY LAID OFF, ON SICK OR OTHER LEAVE} (G1 NOT 3), GO TO G1f BRANCHPOINT

G1c. Do you expect to go back to this job?

1. YES	5. NO	8. DK	9. RF
GO TO G1f BRANCHPOINT			

HRS 2000 — SECTION G: EMPLOYMENT — PAGE 299

FINAL VERSION 3 — 8/13/2002

G1d. In what month and year did you last work on this job?

[IWER: MONTHS ENTERED MUST BE BEFORE OR ON CURRENT IW MONTH, YEAR]

G1d. MONTH:

01. JAN	02. FEB	03. MAR	04. APR	05. MAY	06. JUN	07. JUL
08. AUG	09. SEP	10. OCT	11. NOV	12. DEC	98. DK	99. RF

_____ DK RF

G1e. YEAR

G1f BRANCHPOINT: IF R DID NOT REPORT THAT IS CURRENTLY DISABLED (G1 NOT 4) or IF R WAS DISABLED AT R's LAST IW, GO TO G1h BRANCHPOINT

G1f. In what month and year did you become disabled?

[IWER: DO NOT PROBE FOR MONTH]

[IWER: MONTHS ENTERED MUST BE BEFORE OR ON CURRENT IW MONTH, YEAR]

G1f. MONTH:

01. JAN	02. FEB	03. MAR	04. APR	05. MAY	06. JUN	07. JUL
08. AUG	09. SEP	10. OCT	11. NOV	12. DEC	98. DK	99. RF

_____ DK RF

G1g. YEAR

G1h BRANCHPOINT: IF R DID NOT REPORT THAT IS CURRENTLY RETIRED (G1 NOT 5) or IF R WAS RETIRED AT R's LAST IW, GO TO G2 BRANCHPOINT

G1h. In what month and year did you retire?

G1h. MONTH:

01. JAN	02. FEB	03. MAR	04. APR	05. MAY	06. JUN	07. JUL
08. AUG	09. SEP	10. OCT	11. NOV	12. DEC	98. DK	99. RF

_____ DK RF

G1j. YEAR

G2 BRANCHPOINT: IF R IS WORKING NOW (G1=1), or IS {TEMPORARILY LAID OFF AND EXPECTS TO GO BACK TO WORK (G1c=1)}, ASSIGN 1 FOR G2 AND GO TO G3

IF R IS IN NURSING HOME and DOES NOT OWN HOME OUTSIDE NURSING HOME, ASSIGN 5 FOR G2 AND GO TO G5 BRANCHPOINT

G2. Are you doing any work for pay at the present time?

1. YES	5. NO	8. DK	9. RF
GO TO G5 BRANCHPOINT			

G3. [On the job you plan to go back to/On your current (main) job], do you work for someone else, are you self-employed, or what?

[IWER: IF R SAYS, "I RUN MY OWN BUSINESS" CHOOSE "SELF-EMPLOYED"]

1. SOMEONE ELSE	2. SELF-EMPLOYED	8. DK	9. RF
-----------------	------------------	-------	-------

G5 BRANCHPOINT: IF R IS CURRENTLY WORKING FOR SOMEONE ELSE (G3=1) and WAS WORKING FOR SOMEONE ELSE AT R's LAST IW, GO TO G19b

IF R DID NOT REPORT THAT IS CURRENTLY WORKING FOR SOMEONE ELSE ({G2 & G3} NOT 1) and WAS WORKING FOR SOMEONE ELSE AT R's LAST IW, GO TO G26

IF R WAS SELF-EMPLOYED AT R's LAST IW and DID NOT REPORT THAT IS CURRENTLY SELF-EMPLOYED (G3 NOT 2), CONTINUE ON TO G5

OTHERWISE, GO TO G39 BRANCHPOINT

G5. According to our records, in R's LAST IW MONTH, YEAR you were self-employed.

In what month and year did you stop working for yourself?

[IWER: MONTHS ENTERED MUST BE BETWEEN R's LAST IW MONTH, YEAR AND CURRENT IW MONTH, YEAR.]

G5. MONTH:

01. JAN	02. FEB	03. MAR	04. APR	05. MAY	06. JUN	
07. JUL	08. AUG	09. SEP	10. OCT	11. NOV	12. DEC	
96. STILL WORKING FOR SELF (AS SECOND JOB)		97. DENIES BEING SELF-EMPLOYED AT PREVIOUS IW			98. DK	99. RF
GO TO G5b		GO TO G39 BRANCHPOINT				

DK	RF
----	----

G5a. YEAR

G5b BRANCHPOINT: IF R DID NOT REPORT THAT IS STILL WORKING FOR SELF (AS SECOND JOB) (G5 NOT 96), GO TO G6

G5b. Were there any months since [CURRENT IW MONTH, YEAR 2 YEARS AGO/R's LAST IW MONTH, YEAR] when you were not working for pay?

1. YES	5. NO	8. DK	9. RF
GO TO G39 BRANCHPOINT			

G5c. Which months were those?

[R's PREV WAVE DATE: MONTH, YEAR]

NOTE: MONTH AND YEAR OF R's LAST IW IS DISPLAYED TO IWER.

[IWER: MONTHS ENTERED MUST BE BETWEEN [CURRENT IW MONTH, 1998/R's LAST IW MONTH, YEAR] AND CURRENT IW MONTH, YEAR.]

[IWER: CHOOSE ALL THAT APPLY]

01. JAN 98	02. FEB 98	03. MAR 98	04. APR 98	05. MAY 98	06. JUN 98	07. JUL 98
08. AUG 98	09. SEP 98	10. OCT 98	11. NOV 98	12. DEC 98	13. JAN 99	14. FEB 99
15. MAR 99	16. APR 99	17. MAY 99	18. JUN 99	19. JUL 99	20. AUG 99	21. SEP 99
22. OCT 99	23. NOV 99	24. DEC 99	25. JAN 00	26. FEB 00	27. MAR 00	28. APR 00
29. MAY 00	30. JUN 00	31. JUL 00	32. AUG 00	33. SEP 00	34. OCT 00	35. NOV 00
36. DEC 00	37. JAN 01	38. FEB 01	39. MAR 01	40. ALL OF 1998 (AFTER PREV IW IN HH's LAST IW MONTH)		41. ALL OF 1999
42. ALL OF 1999 (AFTER PREV IW IN HH's LAST IW MONTH)		43. ALL OF 2000 TO DATE		44. ALL OF 1992 (AFTER PREV IW IN HH's LAST IW MONTH)		45. ALL OF 1993
46. ALL OF 1993 (AFTER PREV IW IN HH's LAST IW MONTH)		47. ALL OF 1994		48. ALL OF 1994 (AFTER PREV IW IN HH's LAST IW MONTH)		49. ALL OF 1995
50. ALL OF 1995 (AFTER PREV IW IN HH's LAST IW MONTH)		51. ALL OF 1996		52. ALL OF 1996 (AFTER PREV IW IN HH's LAST IW MONTH)		53. ALL OF 1997
54. ALL OF 1997 (AFTER PREV IW IN HH's LAST IW MONTH)		55. ALL OF 1998		97. OTHER (SPECIFY) _____		98. DK
99. RF						

G6 BRANCHPOINT: GO TO G39 BRANCHPOINT

G6. Were you paid a regular salary or wages?

1. YES	5. NO	8. DK	9. RF
GO TO G7			

G6a. How much were you paid before taxes and other deductions?

[IWER: IF PER HOUR BE SURE TO ADD .00 FOR CENTS IF THERE ARE NONE]

[IWER: PROBE IF NECESSARY]

Was that per hour, week, month, or year?

AMOUNT

DK	RF
GO TO G7	

G6b. PER:

01. HOUR	02. WEEK	03. EVERY TWO WEEKS/BI-WEEKLY	04. MONTH
06. YEAR	97. OTHER (SPECIFY) _____	98. DK	99. RF

G7. Did you receive some or all of the net earnings or profits?

1. YES	5. NO	8. DK	9. RF
GO TO G28			

G7a. (In addition to your regular salary,) How much did you receive from net earnings or profits?

[IWER: IF R HAS TROUBLE GIVING DOLLAR FIGURE, ASK:]

What did you earn the last year you worked?

[IWER: IF PER HOUR BE SURE TO ADD .00 FOR CENTS IF THERE ARE NONE]

[IWER: PROBE IF NECESSARY]

Was that per hour, week, month, or year?

AMOUNT

DK	RF
GO TO G28	

G7b. PER:

01. HOUR	02. WEEK	03. EVERY TWO WEEKS/BI-WEEKLY	04. MONTH
06. YEAR	97. OTHER (SPECIFY) _____	98. DK	99. RF

G19b BRANCHPOINT: GO TO G28

G19b. According to our records, in *R's LAST IW MONTH, YEAR* you were [working for *R's LAST IW EMPLOYER NAME*/also working for someone else].

Are you still working there?

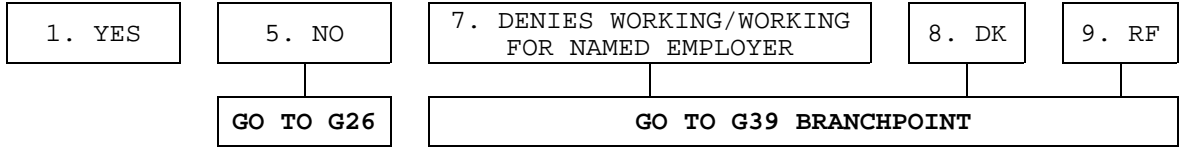

G19d BRANCHPOINT: IF R WORKS FOR SAME EMPLOYER AS R'S LAST IW (G19b=1) and WE KNOW EMPLOYER NAME FROM LAST IW, GO TO G20

G19d. READ TO ALL RESPONDENTS:

We would like to obtain complete information about fringe benefits for employees like you. In order to do this, we need the full name and address of your employer.

IF R IS STILL SELF-EMPLOYED (G5=96):
For whom do you work on your main job?

OTHERWISE:
For whom do you work now?

(What is the [company's/organization's] name?)

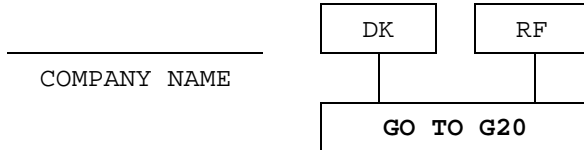

G19f. What is the address of the place where you work?

[IWER: PROBE IF NECESSARY]

I will need the mailing address, city, state, and zip code.

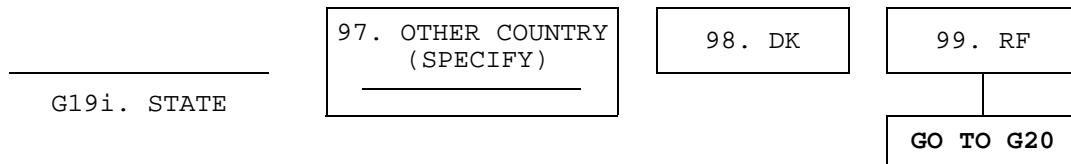
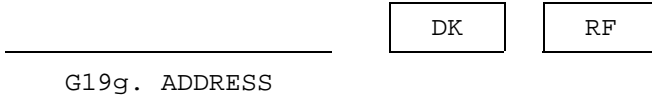
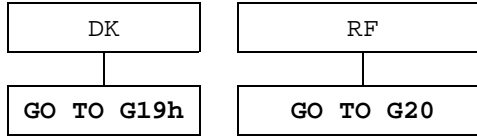

NOTE: THE IWER SELECTS FROM A MENU OF STATE NAMES, INCLUDING WASHINGTON, D.C., AND PUERTO RICO.

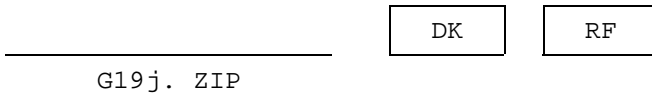

[IWER: DO NOT USE DASH IN PHONE NUMBER]

[IWER: ENTER 999 FOR UNKNOWN AREA CODE OR NUMBER]

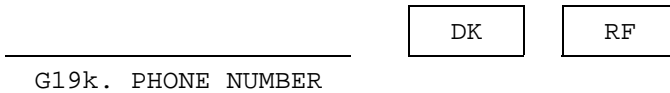

G20. Were there any months since [CURRENT IW MONTH, YEAR 2 YEARS AGO/R's LAST IW MONTH, YEAR] when you did not work for [R's LAST IW EMPLOYER NAME/R's CURRENT EMPLOYER NAME/that employer]?

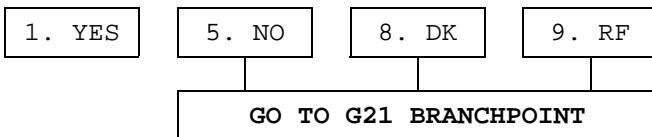

HRS 2000 — SECTION G: EMPLOYMENT — PAGE 306

FINAL VERSION 3 — 8/13/2002

G20a. Which months were those?

IF NEW INTERVIEW R:

[IWER: MONTHS ENTERED MUST BE BETWEEN *CURRENT IW MONTH, YEAR* 2 YEARS AGO AND *CURRENT IW MONTH, YEAR*]

IF REINTERVIEW R:

[IWER: MONTHS ENTERED MUST BE BETWEEN *R's LAST IW MONTH, YEAR* AND *CURRENT IW MONTH, YEAR*]

[IWER: CHOOSE ALL THAT APPLY]

01. JAN 98	02. FEB 98	03. MAR 98	04. APR 98	05. MAY 98	06. JUN 98	07. JUL 98
08. AUG 98	09. SEP 98	10. OCT 98	11. NOV 98	12. DEC 98	13. JAN 99	14. FEB 99
15. MAR 99	16. APR 99	17. MAY 99	18. JUN 99	19. JUL 99	20. AUG 99	21. SEP 99
22. OCT 99	23. NOV 99	24. DEC 99	25. JAN 00	26. FEB 00	27. MAR 00	28. APR 00
29. MAY 00	30. JUN 00	31. JUL 00	32. AUG 00	33. SEP 00	34. OCT 00	35. NOV 00
36. DEC 00	37. JAN 01	38. FEB 01	39. MAR 01	40. ALL OF 1998 (AFTER PREV IW IN <i>HH's LAST IW MONTH</i>)		41. ALL OF 1999
42. ALL OF 1999 (AFTER PREV IW IN <i>HH's LAST IW MONTH</i>)		43. ALL OF 2000 TO DATE		44. ALL OF 1992 (AFTER PREV IW IN <i>HH's LAST IW MONTH</i>)		45. ALL OF 1993
46. ALL OF 1993 (AFTER PREV IW IN <i>HH's LAST IW MONTH</i>)		47. ALL OF 1994		48. ALL OF 1994 (AFTER PREV IW IN <i>HH's LAST IW MONTH</i>)		49. ALL OF 1995
50. ALL OF 1995 (AFTER PREV IW IN <i>HH's LAST IW MONTH</i>)		51. ALL OF 1996		52. ALL OF 1996 (AFTER PREV IW IN <i>HH's LAST IW MONTH</i>)		53. ALL OF 1997
54. ALL OF 1997 (AFTER PREV IW IN <i>HH's LAST IW MONTH</i>)		55. ALL OF 1998		97. OTHER (SPECIFY) _____		98. DK
99. RF						

G21 BRANCHPOINT: IF WE DO NOT HAVE JOB TITLE FROM R's LAST IW, GO TO G41a

G21. In R's LAST IW MONTH, YEAR our records indicate that your job title was R's LAST IW TITLE.

Is this still the case?

[IWER: IF JOB TITLE IS SLIGHTLY INACCURATE BUT DESCRIBES R's CURRENT JOB, ANSWER "YES" HERE AND NOTE CORRECTIONS AS A COMMENT.]

1. YES	5. NO	7. DENIES HAVING THIS JOB TITLE AT PREVIOUS WAVE	8. DK	9. RF
GO TO G44	GO TO G41b BRANCHPOINT		GO TO G41b BRANCHPOINT	

G22. What was your job title in [CURRENT IW MONTH, YEAR 2 YEARS AGO/R's LAST IW MONTH, YEAR]?

[IWER: PROBE]
The title that your employer used?

DK	RF
----	----

TITLE

G23. What sort of work did you do?

[IWER: PROBE]
Tell me a little more about what you did.

DK	RF
----	----

G24. What is your job title now?

[IWER: PROBE]
The title that your employer uses?

DK	RF
----	----

TITLE

G25. What sort of work do you do now?

[IWER: PROBE]

Tell me a little more about what you do.

	DK	RF

G26 BRANCHPOINT: IF R DENIES HAVING PREVIOUSLY LISTED JOB TITLE AT R'S LAST IW (G21=7), GO TO G43 BRANCHPOINT

G26. IF R IS NO LONGER WORKING FOR R'S LAST IW EMPLOYER (G19b=5):
In what month and year did you stop working there?

IF NAME OF R'S LAST IW EMPLOYER IS KNOWN:
According to our records, you were working for R'S LAST IW EMPLOYER NAME in R'S LAST IW MONTH, YEAR.
In what month and year did you stop working there?

OTHERWISE:
According to our records, you were working for someone else when we last talked to you in R'S LAST IW MONTH, YEAR.
In what month and year did you stop working for that employer?

[IWER: MONTHS ENTERED MUST BE BETWEEN R'S LAST IW MONTH, YEAR AND CURRENT IW MONTH, YEAR]

G26. MONTH:

01. JAN	02. FEB	03. MAR	04. APR	05. MAY	06. JUN
07. JUL	08. AUG	09. SEP	10. OCT	11. NOV	12. DEC

96. STILL WORKING FOR PREVIOUS WAVE EMPLOYER	97. DENIES WORKING FOR SOMEONE ELSE, OR FOR NAMED EMPLOYER, AT LAST IW	98. DK	99. RF
GO TO G27 BRANCHPOINT	GO TO G39 BRANCHPOINT		

	DK	RF
--	----	----

G26a. YEAR

G27 BRANCHPOINT: IF R SAID STILL WORKING FOR LAST IW EMPLOYER (G26=96), GO BACK TO G19b AND CHANGE RESPONSE TO YES (G19b=1)

G27. What were you earning, before deductions, when you left that employer?

[IWER: IF PER HOUR BE SURE TO ADD .00 FOR CENTS IF THERE ARE NONE]

[IWER: PROBE IF NECESSARY]

Was that per hour, week, month, or year?

_____	DK	RF
AMOUNT		
GO TO G28		

27a. PER:

01. HOUR	02. WEEK	03. EVERY TWO WEEKS/BI-WEEKLY	04. MONTH
06. YEAR	97. OTHER (SPECIFY) _____	98. DK	99. RF

G28. IF NOT SELF-EMPLOYED AT LAST IW:
Why did you leave that employer?

(Did the business close, were you laid off or let go, did you leave to take care of family members, or what?)

IF SELF-EMPLOYED AT LAST IW:
Why did you stop working at that business?

[IWER: DO NOT PROBE BUT CHOOSE ALL THAT APPLY]

01. BUSINESS CLOSED	02. LAID OFF/LET GO	03. POOR HEALTH/DISABLED	04. FAMILY CARE	05. BETTER JOB
GO TO G29 BRANCHPOINT	GO TO G28d			
06. QUIT	07. RETIRED	97. OTHER (SPECIFY) _____	98. DK	99. RF

G28a BRANCHPOINT: IF R WAS SELF-EMPLOYED AT R's LAST IW, GO TO G29 BRANCHPOINT

G28a. Did your employment situation change in some way that encouraged you to leave?

1. YES	5. NO	8. DK	9. RF
GO TO G28c			

G28b. How did it change?

[IWER: CHOOSE ALL THAT APPLY]

01. SUPERVISOR ENCOURAGED DEPARTURE	02. COWORKER ENCOURAGED DEPARTURE	03. WAGES REDUCED (OR ABOUT TO BE REDUCED)	04. HOURS REDUCED (OR ABOUT TO BE REDUCED)
			GO TO G28d
05. WOULD HAVE BEEN LAID OFF	06. NEW JOB DUTIES	07. NEW JOB LOCATION	08. BECAME ELIGIBLE FOR PENSION
09. EMPLOYER CHANGED HEALTH INSURANCE		10. SPECIAL EARLY RETIREMENT INCENTIVE OFFER	
97. OTHER (SPECIFY) _____	98. DK	99. RF	

G28c. If your employer had allowed you to work fewer hours with correspondingly less pay, would you have continued working there?

1. YES	5. NO	8. DK	9. RF
--------	-------	-------	-------

G28d. Did your employer experience a permanent reduction in employment between [CURRENT IW MONTH, YEAR 2 YEARS AGO/R's LAST IW MONTH, YEAR] and the time you were leaving?

[IWER: PERMANENT EMPLOYMENT REDUCTIONS ARE SOMETIMES CALLED "DOWNSIZING"; "LAYOFFS" CAN BE PERMANENT OR TEMPORARY.]

1. YES	5. NO	8. DK	9. RF
--------	-------	-------	-------

G29 BRANCHPOINT IF R STOPPED WORKING FOR {LAST IW EMPLOYER or SELF} {ONE MONTH OR LESS} AFTER R's LAST IW (per {G26/G26a or G5/G5a}) or R DID NOT SAY WHEN S/HE STOPPED WORKING FOR {LAST IW EMPLOYER or SELF} ({G26 or G26a}={DK or RF} or {G5 or G5a}={DK or RF}), GO TO G30 BRANCHPOINT

G29. Were there any months between R's LAST IW MONTH, YEAR and MONTH, YEAR R STOPPED WORKING FOR [EMPLOYER (per G26&G26a)/SELF (per G5&G5a)] when you did not work [at this business/for this employer]?

1. YES	5. NO	8. DK	9. RF
GO TO G30 BRANCHPOINT			

HRS 2000 — SECTION G: EMPLOYMENT — PAGE 311

FINAL VERSION 3 — 8/13/2002

G29a. Which months were those?

[IWER: MONTHS ENTERED MUST BE BETWEEN R's LAST IW MONTH, YEAR AND MONTH, YEAR R STOPPED WORKING FOR [EMPLOYER (per G26&G26a)/SELF (per G5&G5a)]]

[IWER: CHOOSE ALL THAT APPLY]

01. JAN 98	02. FEB 98	03. MAR 98	04. APR 98	05. MAY 98	06. JUN 98	07. JUL 98
08. AUG 98	09. SEP 98	10. OCT 98	11. NOV 98	12. DEC 98	13. JAN 99	14. FEB 99
15. MAR 99	16. APR 99	17. MAY 99	18. JUN 99	19. JUL 99	20. AUG 99	21. SEP 99
22. OCT 99	23. NOV 99	24. DEC 99	25. JAN 00	26. FEB 00	27. MAR 00	28. APR 00
29. MAY 00	30. JUN 00	31. JUL 00	32. AUG 00	33. SEP 00	34. OCT 00	35. NOV 00
36. DEC 00	37. JAN 01	38. FEB 01	39. MAR 01	40. ALL OF 1998 (AFTER PREV IW IN HH'S LAST IW MONTH)		41. ALL OF 1999
42. ALL OF 1999 (AFTER PREV IW IN HH'S LAST IW MONTH)		43. ALL OF 2000 TO DATE		44. ALL OF 1992 (AFTER PREV IW IN HH'S LAST IW MONTH)		45. ALL OF 1993
46. ALL OF 1993 (AFTER PREV IW IN HH'S LAST IW MONTH)		47. ALL OF 1994		48. ALL OF 1994 (AFTER PREV IW IN HH'S LAST IW MONTH)		49. ALL OF 1995
50. ALL OF 1995 (AFTER PREV IW IN HH'S LAST IW MONTH)		51. ALL OF 1996		52. ALL OF 1996 (AFTER PREV IW IN HH'S LAST IW MONTH)		53. ALL OF 1997
54. ALL OF 1997 (AFTER PREV IW IN HH'S LAST IW MONTH)		55. ALL OF 1998		97. OTHER (SPECIFY) _____		98. DK
99. RF						

G30 BRANCHPOINT: IF R HAD PENSION PLAN ON JOB AT R'S LAST IW, ASSIGN 1 TO G30 AND GO TO G30a

G30. IF NOT SELF-EMPLOYED AT R's LAST IW:
Were you included in a pension or retirement plan, or in any tax deferred savings plan, when you worked for [R's LAST IW EMPLOYER NAME/R's CURRENT EMPLOYER NAME/that employer]?

OTHERWISE:

Aside from IRAs or KEOGH plans, were you included in a pension or retirement plan, or in any tax deferred savings plan, through your work?

1. YES	5. NO	8. DK	9. RF
GO TO G39 BRANCHPOINT			

G30a. IF R REPORTED AT LAST IW THAT WAS INCLUDED IN PENSION PLAN ON THIS JOB:
According to our records, you reported that you were included in one or more pension plans on this job.
In how many different pension plans were you included on this job?

[IWER: ENTER "95" IF R DENIES BEING INCLUDED IN ANY PENSION PLAN]

OTHERWISE:

In how many different pension plans were you included on this job?

_____	0	95. DENIES BEING INCLUDED IN PENSION PLAN	DK	RF
NUMBER OF PLANS	GO TO G39 BRANCHPOINT			

BEGINNING OF G31 LOOP: QUESTIONS G31 THROUGH G38 ARE REPEATED FOR UP TO FOUR PENSION PLANS.

G31. IF THIS IS THE FIRST PLAN AND R HAS MORE THAN ONE PLAN (G30a ≥ 2):
Now I have some questions about the most important of these plans.
I would like to know what type of plan this was.

IF THIS IS THE SECOND, THIRD OR FOURTH PLAN:
Now I have some questions about the next most important of these plans.
I would like to know what type of plan this was.

IF R HAS ONLY ONE PLAN (G30a=1):
I would like to know what type of plan this was.

(In some retirement plans, Type A, benefits are usually based on a formula involving age, years of service and salary. In other plans, Type B, money is accumulated in an account for you.)

Was your plan Type A or Type B?

DEFINITION: 401-K, 403-B, ESOP, SRA, THRIFT/SAVINGS, STOCK/PROFIT SHARING, MONEY PURCHASE PLANS ARE ALL TYPE B RETIREMENT PLANS. TYPE A PLANS ARE OFTEN CALLED "DEFINED BENEFIT" PLANS; TYPE B PLANS ARE OFTEN CALLED "DEFINED CONTRIBUTION."

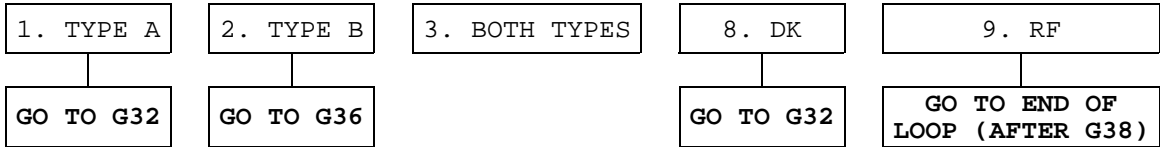

G31a. For the part of your pension where money is accumulated in an account, how much money was in your account when you left that [business/employer]?

AMOUNT

DK	RF
----	----

G31b. When you left that [business/employer], did you withdraw the money, roll it over into an IRA, leave it to accumulate in the old plan, convert it to an annuity, or what?

[IWER: DO NOT PROBE, BUT IF MORE THAN ONE RESPONSE GIVEN, CHOOSE 7 - OTHER, AND RECORD ALL DETAILS.]

1. WITHDREW THE MONEY	2. ROLLED OVER INTO IRA	3. LEFT TO ACCUMULATE	4. CONVERT TO ANNUITY
GO TO G32			GO TO G31d
7. OTHER (SPECIFY) _____	8. DK	9. RF	
GO TO G32			

G31c. How much is in your account now?

_____	DK	RF
AMOUNT		
GO TO G32		

G31d. How old were you when you started receiving the benefits from that annuity?

[IWER: IF R INDICATES BENEFITS HAVE NOT YET STARTED, ASK AT WHAT AGE THEY WILL BEGIN, AND NOTE THIS IN COMMENT BOX.]

_____	DK	RF
AGE		

G31e. How much are the benefits per month or year?

[IWER: PROBE IF NECESSARY]
Was that per month or year?

[IWER: IF BENEFITS HAVE NOT YET STARTED, RECORD WHAT BENEFITS WILL BE.]

_____	DK	RF
AMOUNT		
GO TO G32		

G31f. PER:

01. HOUR	02. WEEK	03. EVERY TWO WEEKS/BI-WEEKLY	04. MONTH
06. YEAR	97. OTHER (SPECIFY) _____	98. DK	99. RF

G32. IF R's PLAN IS BOTH TYPE A AND TYPE B (G31=3):
Now, about the part of your pension where benefits are based on a
formula.

ASK ALL Rs:

Do you expect to receive benefits from this plan in the future, are you
receiving benefits now, did you get a cash settlement when you left, did
you lose your benefits, or what?

[IWER: DO NOT PROBE BUT CHOOSE ALL THAT APPLY AND ASK ALL APPROPRIATE
FOLLOW-UP QUESTIONS.]

1. EXPECT FUTURE BENEFITS	2. RECEIVING BENEFITS NOW	3. RECEIVED CASH SETTLEMENT	4. ROLLED OVER INTO IRA
5. LOST BENEFITS	7. OTHER (SPECIFY) _____	8. DK	9. RF

G32a BRANCHPOINT: IF R DID NOT REPORT THAT IS RECEIVING BENEFITS NOW
(G32 NOT 2), GO TO G32g BRANCHPOINT

G32a. In what month and year did you start to receive these benefits?

G32a. MONTH:

01. JAN	02. FEB	03. MAR	04. APR	05. MAY	06. JUN	07. JUL
08. AUG	09. SEP	10. OCT	11. NOV	12. DEC	98. DK	99. RF

_____ DK RF

G32b. YEAR

G32c. How much are the benefits per month or year?

[IWER: PROBE IF NECESSARY]
Was that per month or year?

_____ DK RF

AMOUNT

GO TO G32e

G32d. PER:

01. HOUR	02. WEEK	03. EVERY TWO WEEKS/BI-WEEKLY	04. MONTH
06. YEAR	97. OTHER (SPECIFY) _____	98. DK	99. RF

G32e. Are the benefits adjusted for changes in the cost of living?

1. YES	5. NO	8. DK	9. RF
--------	-------	-------	-------

G32g BRANCHPOINT: IF R DID NOT REPORT THAT RECEIVED A CASH SETTLEMENT WHEN LEFT JOB (G32 NOT 3), GO TO G32j BRANCHPOINT

G32g. How much did the cash settlement amount to?

_____ DK RF

AMOUNT

G32h. What did you do with the money?

1. BOUGHT DURABLES	2. SPENT IT	3. SAVED/INVESTED	4. PAID OFF DEBT
5. ROLLED INTO IRA	7. OTHER (SPECIFY) _____	8. DK	9. RF

G32j BRANCHPOINT: IF R DID NOT REPORT THAT ROLLED PENSION OVER INTO IRA WHEN LEFT JOB (G32 NOT 4), GO TO G34 BRANCHPOINT

G32j. How much did the rollover amount to?

AMOUNT

DK	RF
----	----

G34 BRANCHPOINT: IF R DID NOT REPORT THAT EXPECTS FUTURE BENEFITS FROM PENSION FROM FORMER JOB (G32 NOT 1), GO TO G38

G34. At what age do you expect to start receiving (the rest of your) benefits from this plan?

AGE

96. ALREADY RECEIVING ALL BENEFITS	DK	RF
------------------------------------	----	----

GO TO G38

G35. About how much do you expect these benefits to be, either as a percent of your pay when you left that job, or as an amount per month or year when you start receiving them?

1. PERCENT OF PAY	2. AMOUNT PER MONTH/YEAR	3. LUMP SUM	8. DK	9. RF
-------------------	--------------------------	-------------	-------	-------

GO TO G35b GO TO G35d GO TO G38

G35a. ENTER THE PERCENT OF FINAL PAY:

PERCENT

DK	RF
----	----

GO TO G38

G35b. [IWER: PROBE IF NECESSARY]
How much do you expect to receive?

[IWER: PROBE IF NECESSARY]
Was that per month or year?

AMOUNT

DK	RF
----	----

GO TO G38

G35c. PER:

01. HOUR	02. WEEK	03. EVERY TWO WEEKS/BI-WEEKLY	04. MONTH
----------	----------	-------------------------------	-----------

GO TO G38

06. YEAR	97. OTHER (SPECIFY) _____	98. DK	99. RF
----------	------------------------------	--------	--------

GO TO G38

G35d. ENTER LUMP SUM AMOUNT:

AMOUNT

DK	RF
----	----

GO TO G38

G37. When you left that [business/employer], did you withdraw the money, roll it over into an IRA, leave it to accumulate in your old plan, convert it to an annuity, or what?

[IWER: DO NOT PROBE, BUT IF MORE THAN ONE RESPONSE GIVEN, CHOOSE 7 - OTHER, AND RECORD ALL DETAILS.]

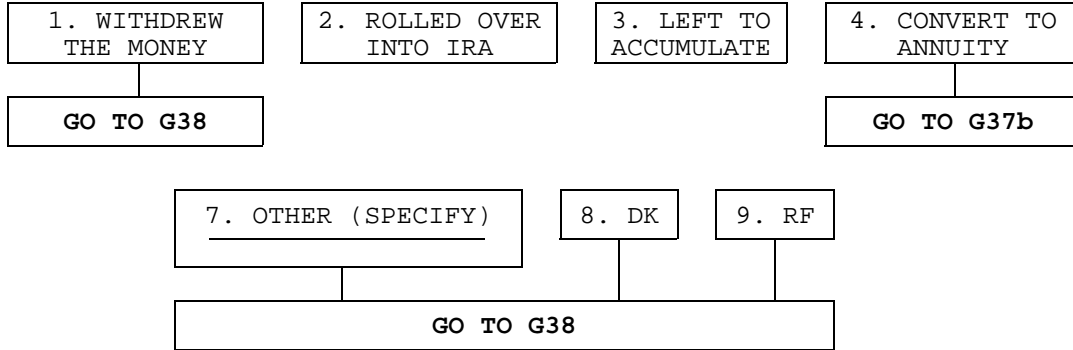

G37a. How much is in your account now?

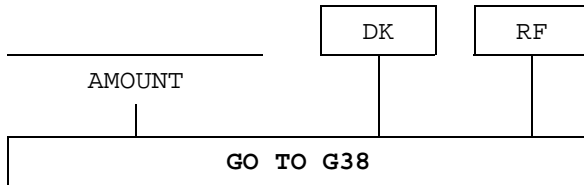

G37b. How old were you when you started receiving the benefits from that annuity?

[IWER: IF R INDICATES BENEFITS HAVE NOT YET STARTED, ASK AT WHAT AGE THEY WILL BEGIN, AND NOTE THIS IN COMMENT BOX.]

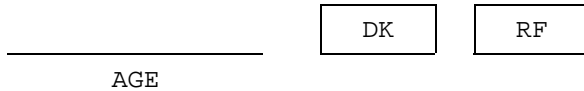

G37c. How much are the benefits per month or year?

[IWER: PROBE IF NECESSARY]
Was that per month or year?

[IWER: IF BENEFITS HAVE NOT YET STARTED, RECORD WHAT BENEFITS WILL BE.]

AMOUNT

DK	RF
GO TO G38	

G37d. PER:

01. HOUR	02. WEEK	03. EVERY TWO WEEKS/BI-WEEKLY	04. MONTH
06. YEAR	97. OTHER (SPECIFY) _____	98. DK	99. RF

G38. What is the earliest age at which you could have left that [business/employer] and begun to receive pension benefits from this plan?

AGE

95. NO AGE REQUIREMENT	DK	RF
------------------------	----	----

END OF G31 LOOP: IF THERE ARE MORE PENSION PLANS GIVEN, REPEAT QUESTIONS G31 THROUGH G38 FOR UP TO FOUR PENSION PLANS. IF NOT, CONTINUE ON TO G39 BRANCHPOINT.

<p>G39 BRANCHPOINT: IF R IS IN NURSING HOME and HAS NO RESIDENCE OUTSIDE OF NURSING HOME, GO TO G141 BRANCHPOINT</p> <p>IF R DID NOT REPORT THAT IS CURRENTLY WORKING (G2 NOT 1), GO TO G115</p> <p>IF R IS CURRENTLY SELF-EMPLOYED (G3=2), GO TO G41a</p>
--

G39. READ TO ALL RESPONDENTS:
We would like to obtain complete information about fringe benefits for employees like you. In order to do this, we need the full name and address of your employer.

For whom do you work [now/on your main job]?

(What is the [company's/organization's] name?)

COMPANY

DK	RF
GO TO G41a	

G40. What is the address of the place where you work?

[IWER: PROBE IF NECESSARY]

I will need the mailing address, city, state, and zip code.

	<input type="text" value="DK"/>	<input type="text" value="RF"/>
	<input type="text" value="GO TO G40b"/>	<input type="text" value="GO TO G41a"/>
_____	<input type="text" value="DK"/>	<input type="text" value="RF"/>
G40a. ADDRESS		
_____	<input type="text" value="DK"/>	<input type="text" value="RF"/>
G40b. CITY		<input type="text" value="GO TO G41a"/>
_____	<input type="text" value="97. OTHER COUNTRY
(SPECIFY)
_____"/>	<input type="text" value="98. DK"/>
G40c. STATE		<input type="text" value="99. RF"/>
		<input type="text" value="GO TO G41a"/>

NOTE: THE IWER SELECTS FROM A MENU OF STATE NAMES, INCLUDING WASHINGTON, D.C., AND PUERTO RICO.

_____	<input type="text" value="DK"/>	<input type="text" value="RF"/>
G40d. ZIP		

[IWER: DO NOT USE DASH IN PHONE NUMBER]

[IWER: ENTER 999 FOR UNKNOWN AREA CODE OR NUMBER]

_____	<input type="text" value="DK"/>	<input type="text" value="RF"/>
G40e. PHONE NUMBER		

G41a. IF NOT SELF-EMPLOYED (G3 NOT 2):

What kind of business or industry do you work in — that is, what do they make or do at the place where you work?

IF SELF-EMPLOYED (G3=2):

Now I have a few questions about your current business.

What industry do you work in? That is, what does your company do or make?

(What industry do you typically work in?)

_____ DK RF
INDUSTRY

G41b BRANCHPOINT: IF R IS CURRENTLY SELF-EMPLOYED (G3=2), GO TO G42

G41b. What is the official title of your job?

(The title that your employer uses?)

_____ DK RF
TITLE

G42. What sort of work do you do?

(Tell me a little more about what you do.)

_____ DK RF

TYPE OF WORK

G43 BRANCHPOINT: IF R IS CURRENTLY SELF-EMPLOYED (G3=2), GO TO G44

G43. In what month and year did you start doing this kind of work, including work for previous employers?

[IWER: MONTHS ENTERED MUST BE BEFORE OR ON CURRENT IW MONTH, YEAR]

G43. MONTH:

01. JAN	02. FEB	03. MAR	04. APR	05. MAY	06. JUN	07. JUL
08. AUG	09. SEP	10. OCT	11. NOV	12. DEC	98. DK	99. RF

G43a. YEAR

G44. How many hours a week do you usually work [on this job/in this business]?

HOURS

G45 BRANCHPOINT: IF R IS CURRENTLY SELF-EMPLOYED (G3=2), GO TO G47

G45. Do you work [the same/this] number of hours nearly every week, or do the hours you work vary a lot from week to week?

IF VARIATION IS DUE TO NOT WORKING AT ALL IN SOME WEEKS: PROBE —
These questions are about times when you are working.

1. SAME EACH WEEK/THIS NUMBER	2. VARY A LOT	8. DK	9. RF
<input type="text" value="GO TO G46"/>		<input type="text" value="GO TO G46"/>	

G45a. How many hours would you work in a week with relatively long hours?

HOURS

G45b. How many hours in a relatively short week?

HOURS

G46. How many weeks of paid vacation do you get each year?

AMOUNT

NONE	DK	RF
ASSIGN 6 TO G46b AND GO TO G47		

G46b. TIME UNIT:

1. DAYS	2. WEEKS	4. MONTHS	6. NONE
7. OTHER (SPECIFY) _____		8. DK	9. RF

G47. READ SLOWLY:

(Counting paid vacations as weeks of work,) how many weeks a year do you usually work on this job?

[IWER: COUNT PAID SICK TIME AS WORK TIME]

WEEKS

	DK	RF
--	----	----

G48. In the last 12 months, did you miss any days from work because of your health?

1. YES	5. NO	8. DK	9. RF
GO TO G49 BRANCHPOINT			

G48a. About how many days did you miss?

DAYS

	DK	RF
--	----	----

G49 BRANCHPOINT: IF R IS CURRENTLY SELF-EMPLOYED (G3=2), GO TO G52

G49. How many days of paid sick leave at full pay do you earn each year?

DAYS

	995. NO SET NUMBER	DK	RF
--	-----------------------	----	----

G50. Does your employer provide coverage for long-term disability on this job?

1. YES	5. NO	8. DK	9. RF
--------	-------	-------	-------

G51 BRANCHPOINT: IF R HAS SAME {EMPLOYER AND JOB TITLE} AS R'S LAST IW (G21=1), GO TO G56

G51. On your job, do you make decisions about the pay and promotion of others?

1. YES	5. NO	8. DK	9. RF
GO TO G56			

G51a. For how many people do you make pay and promotion decisions?

_____	DK	RF
NUMBER OF PEOPLE		
GO TO G56		

G52. Are you paid a regular salary or wages?

1. YES	5. NO	8. DK	9. RF
GO TO G53			

G52a. How much are you paid before taxes and other deductions?

[IWER: IF PER HOUR BE SURE TO ADD .00 FOR CENTS IF THERE ARE NONE]

[IWER: USE ZERO FOR NONE]

_____	DK	RF
AMOUNT		
GO TO G53		

G52b. PER:

01. HOUR	02. WEEK	03. EVERY TWO WEEKS/BI-WEEKLY	04. MONTH
06. YEAR	97. OTHER (SPECIFY) _____	98. DK	99. RF

G53. Do you receive some or all of the net earnings or profits?

1. YES	5. NO	8. DK	9. RF
GO TO G54			

G53a. IF R IS PAID REGULAR SALARY OR WAGES (G52=1):
 In addition to your regular salary, how much do you receive from net earnings or profits?

OTHERWISE:
 How much do you receive from net earnings or profits?

[IWER: IF R HAS TROUBLE GIVING DOLLAR FIGURE, ASK:]
 What did you earn the last year you worked?

[IWER: IF PER HOUR BE SURE TO ADD .00 FOR CENTS IF THERE ARE NONE]

[IWER: USE ZERO FOR NONE]

_____	DK	RF
AMOUNT	GO TO G54	

G53b. PER:

01. HOUR	02. WEEK	03. EVERY TWO WEEKS/BI-WEEKLY	04. MONTH
06. YEAR	97. OTHER (SPECIFY) _____	98. DK	99. RF

G54. Including yourself, how many people work in this business?

_____	DK	RF
NUMBER OF PEOPLE		

G55a BRANCHPOINT: IF {R HAS SAME SPOUSE/PARTNER AS R's LAST IW and R WAS SELF-EMPLOYED AT R's LAST IW} or R IS NOT MARRIED/PARTNERED, GO TO G63

G55a. Does your [husband/wife/partner] do any work for the business?

1. YES	5. NO	8. DK	9. RF
GO TO G63			

G55b. How many hours a week does [he/she] usually work for the business?

DK	RF
----	----

NUMBER OF HOURS

G55c. Is [he/she] paid a regular salary?

1. YES	5. NO	8. DK	9. RF
--------	-------	-------	-------

GO TO G63

G56. Are you salaried on this job, paid by the hour, or what?

1. SALARIED	2. HOURLY	3. PIECEWORK/COMMISSION
-------------	-----------	-------------------------

GO TO G56f GO TO G56m

7. OTHER/COMBINATION	8. DK	9. RF
----------------------	-------	-------

GO TO G56q BRANCHPOINT GO TO G56r GO TO G57

G56a. How much is your salary, before taxes and other deductions?

[IWER: IF PER HOUR BE SURE TO ADD .00 FOR CENTS IF THERE ARE NONE]

[IWER: PROBE IF NECESSARY]

Is that per hour, week, month, or year?

DK	RF
----	----

AMOUNT

GO TO G56c

G56b. PER:

01. HOUR	02. WEEK	03. EVERY TWO WEEKS/BI-WEEKLY	04. MONTH
----------	----------	-------------------------------	-----------

06. YEAR	97. OTHER (SPECIFY) _____	98. DK	99. RF
----------	------------------------------	--------	--------

G56c. If you were to work more hours than usual during some weeks, would you get paid for those extra hours, get time off later, or get no compensation for the extra hours?

[IWER: IF TREATMENT OF OVERTIME DIFFERS (E.G., DEPENDING ON DAY OF WEEK) PROBE FOR MOST FREQUENT OR MOST IMPORTANT OUTCOME.]

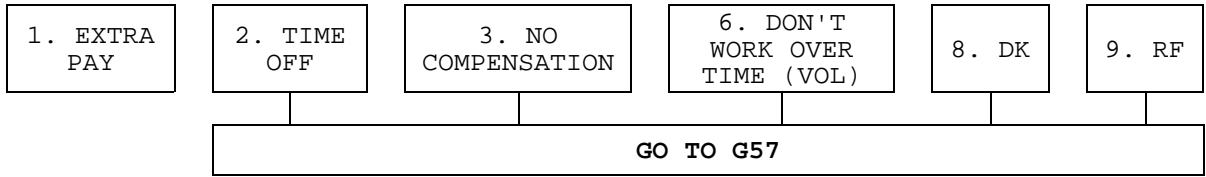

G56d. About how much would you make per hour for those extra hours?

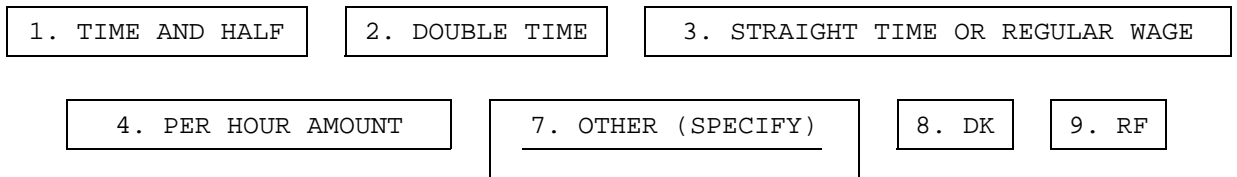

G56e BRANCHPOINT: IF R's OVERTIME RATE WAS NOT A PER HOUR AMOUNT (G56d NOT 4), GO TO G57

G56e. [IWER: PROBE IF NECESSARY]
How much would you make per hour for each extra hour?

[IWER: BE SURE TO ENTER .00 FOR CENTS IF THERE ARE NONE]

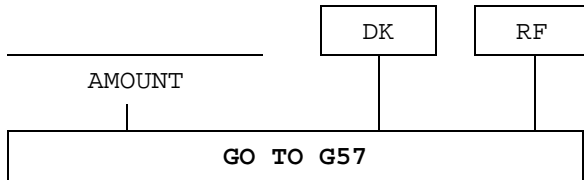

G56f. What is your hourly wage rate for regular work time?

[IWER: IF PER HOUR BE SURE TO ADD .00 FOR CENTS IF THERE ARE NONE]

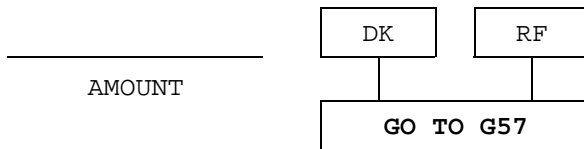

G56g. What is your hourly wage rate for overtime?

[IWER: IF TREATMENT OF OVERTIME DIFFERS (E.G., DEPENDING ON DAY OF WEEK) PROBE FOR MOST FREQUENT OR MOST IMPORTANT OUTCOME.]

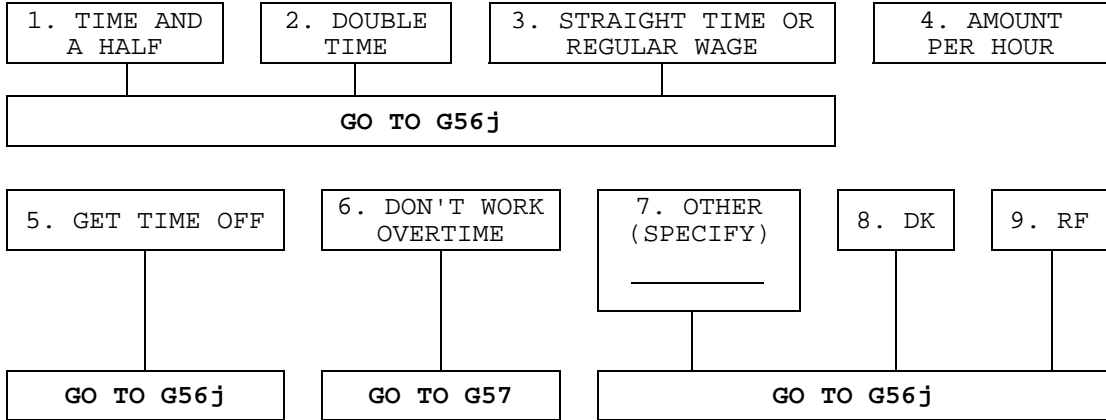

G56Y1g. (What is your hourly wage rate for overtime?)

[IWER: BE SURE TO ADD .00 FOR CENTS IF THERE ARE NONE]

AMOUNT

G56j. During the last year, in how many weeks did you work some overtime?

WEEKS

G56k. Are you required to work overtime, or it is pretty much up to you?

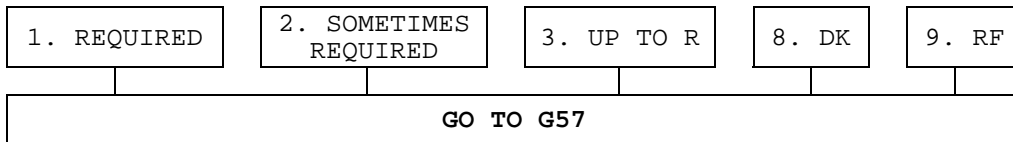

G56m. What does that amount to, before taxes and other deductions, in an average week or month?

[IWER: PROBE IF NECESSARY]
Was that per week or month?

AMOUNT

DK	RF
GO TO G57	

G56n. PER:

01. HOUR	02. WEEK	03. EVERY TWO WEEKS/BI-WEEKLY	04. MONTH
06. YEAR	97. OTHER (SPECIFY) _____	98. DK	99. RF

G56p. If you worked an extra hour, how much would you earn for that?

[IWER: BE SURE TO ADD .00 FOR CENTS IF THERE ARE NONE]

AMOUNT

0. NO EXTRA PAY OR TIME OFF	999995. GET TIME OFF INSTEAD	DK	RF
-----------------------------	------------------------------	----	----

G56q BRANCHPOINT: IF R IS WORKING NOW FOR PAY (WAS ASKED G56) and DID NOT ANSWER "OTHER/COMBINATION" TO HOW S/HE IS PAID (G56 NOT 7), GO TO G57

G56q. How are you paid?

HOW PAID

DK	RF
----	----

G56r. How much are you paid before taxes and other deductions?

[IWER: IF PER HOUR BE SURE TO ADD .00 FOR CENTS IF THERE ARE NONE]

[IWER: PROBE IF NECESSARY]

Was that per hour, week, month, or year?

AMOUNT

DK	RF
GO TO G57	

G56s. PER:

01. HOUR	02. WEEK	03. EVERY TWO WEEKS/BI-WEEKLY	04. MONTH
06. YEAR	97. OTHER (SPECIFY) _____	98. DK	99. RF

G56t. If you worked an extra hour, how much would you earn for that hour?

[IWER: IF PER HOUR BE SURE TO ADD .00 FOR CENTS IF THERE ARE NONE]

AMOUNT

0. NO EXTRA PAY OR TIME OFF	99995. GET TIME OFF INSTEAD	DK	RF
-----------------------------	-----------------------------	----	----

G57. (Not counting overtime hours), Could you reduce the number of paid hours in your regular work schedule?

1. YES	5. NO	8. DK	9. RF
--------	-------	-------	-------

G57a BRANCHPOINT: IF R IS ABLE TO REDUCE WORK HOURS (G57=1) and R WORKS {30 OR MORE} HOURS PER WEEK (G44 ≥ 30), GO TO G59

IF R IS ABLE TO REDUCE WORK HOURS (G57=1) and R DID NOT REPORT WORKING AT LEAST 30 HOURS PER WEEK (G44 {<30 or = {DK or RF}}), GO TO G60

G57a. Would you like to do so even if your earnings were reduced in the same proportion?

1. YES	5. NO	8. DK	9. RF
GO TO G60			

G57b. How many hours would you like to work each week?

NUMBER OF HOURS

DK RF

GO TO G60

G59. If you wanted to work half time or less on this job, would your employer allow you to do that?

1. YES 3. ONLY TEMPORARILY 5. NO 8. DK 9. RF

GO TO G60

G59a. Would your pay be cut in proportion to your hours, more than that, or less than that?

1. IN PROPORTION 2. MORE 3. LESS 8. DK 9. RF

G59b. Would your health insurance benefits be reduced, eliminated, or kept the same?

1. REDUCED 2. ELIMINATED 3. KEPT THE SAME

6. DOESN'T HAVE HEALTH INSURANCE BENEFITS 8. DK 9. RF

G59c. Would your eligibility for pension benefits be affected?

1. YES 5. NO 6. DOESN'T HAVE PENSION BENEFITS 8. DK 9. RF

G60. Could you increase the number of paid hours in your regular work schedule?

1. YES 5. NO 8. DK 9. RF

GO TO G61

G60a. Would you like to do so if your earnings were increased in the same proportion?

1. YES 5. NO 8. DK 9. RF

GO TO G61

G60b. How many hours would you like to work each week?

NUMBER OF HOURS

G61. About how many employees work for this company or organization at the location where you work?

[IWER: DO NOT PROBE DK/RF]

NUMBER OF EMPLOYEES

G61a. Is it fewer than 5, 5 to 14, 15 to 24, 25 to 99, 100 to 499, or 500 or more?

G62. About how many employees work for this company or organization at all locations?

[IWER: THE NUMBER MUST BE AT LEAST AS LARGE AS G61]

[IWER: DON'T PROBE "DON'T KNOW"]

[IWER: ENTER "0" IF ONLY ONE LOCATION]

NUMBER OF EMPLOYEES

G62a BRANCHPOINT: IF AT LEAST 500 EMPLOYEES WORK AT R'S LOCATION (G61≥500 or G61a=6), GO TO G63

G62a. Is it fewer than 5, 5 to 14, 15 to 24, 25 to 99, 100 to 499, or 500 or more?

G63. In what month and year did you start working for [this business/this employer]?

[IWER: IF R WORKED MORE THAN ONCE FOR THIS EMPLOYER, ASK ABOUT FIRST HIRE.]

IF THIS IS A REINTERVIEW R AND SECOND R:

[IWER: IF DATE GIVEN IS BEFORE R'S LAST IW MONTH, YEAR, PLEASE VERIFY WITH R]

G63. MONTH:

01. JAN	02. FEB	03. MAR	04. APR	05. MAY	06. JUN	07. JUL
08. AUG	09. SEP	10. OCT	11. NOV	12. DEC	98. DK	99. RF

DK	RF
----	----

G63a. YEAR

G65 BRANCHPOINT: IF R IS STILL WORKING FOR SAME EMPLOYER AS IN R'S LAST IW (G19b=1), GO TO G65b BRANCHPOINT

IF THIS IS A NEW INTERVIEW R, GO TO G65b BRANCHPOINT

IF R STARTED WORKING FOR CURRENT EMPLOYER LESS THAN 2 MONTHS FROM {MONTH and YEAR} OF CURRENT IW (per G63/G63a) or WE DON'T KNOW BOTH (MONTH and YEAR) WHEN R STARTED CURRENT JOB ({G63 or G63a}={DK or RF}), GO TO G65b BRANCHPOINT

G65. Were there any months since [MONTH, YEAR R STARTED CURRENT JOB/R'S LAST IW MONTH, YEAR/in the last two years] when you did not work for this [business/employer]?

1. YES	5. NO	8. DK	9. RF
GO TO G65b BRANCHPOINT			

G65a. Which months were those?

[IWER: MONTHS ENTERED MUST BE [MONTH, YEAR R STARTED CURRENT JOB/R'S LAST IW MONTH, YEAR/CURRENT IW MONTH, YEAR 2 YEARS AGO] AND CURRENT IW MONTH, YEAR.]

[IWER: CHOOSE ALL THAT APPLY]

01. JAN 98	02. FEB 98	03. MAR 98	04. APR 98	05. MAY 98	06. JUN 98	07. JUL 98
08. AUG 98	09. SEP 98	10. OCT 98	11. NOV 98	12. DEC 98	13. JAN 99	14. FEB 99
15. MAR 99	16. APR 99	17. MAY 99	18. JUN 99	19. JUL 99	20. AUG 99	21. SEP 99
22. OCT 99	23. NOV 99	24. DEC 99	25. JAN 00	26. FEB 00	27. MAR 00	28. APR 00
29. MAY 00	30. JUN 00	31. JUL 00	32. AUG 00	33. SEP 00	34. OCT 00	35. NOV 00
36. DEC 00	37. JAN 01	38. FEB 01	39. MAR 01	40. ALL OF 1998 (AFTER PREV IW IN HH'S LAST IW MONTH)		41. ALL OF 1999
42. ALL OF 1999 (AFTER PREV IW IN HH'S LAST IW MONTH)		43. ALL OF 2000 TO DATE		44. ALL OF 1992 (AFTER PREV IW IN HH'S LAST IW MONTH)		45. ALL OF 1993
46. ALL OF 1993 (AFTER PREV IW IN HH'S LAST IW MONTH)		47. ALL OF 1994		48. ALL OF 1994 (AFTER PREV IW IN HH'S LAST IW MONTH)		49. ALL OF 1995
50. ALL OF 1995 (AFTER PREV IW IN HH'S LAST IW MONTH)		51. ALL OF 1996		52. ALL OF 1996 (AFTER PREV IW IN HH'S LAST IW MONTH)		53. ALL OF 1997
54. ALL OF 1997 (AFTER PREV IW IN HH'S LAST IW MONTH)		55. ALL OF 1998		97. OTHER (SPECIFY) _____		98. DK
						99. RF

NOTE: THE ONLY CHOICES PRESENTED TO THE IWER ARE THOSE FOR MONTHS AND/OR YEARS FROM R'S LAST IW DATE UNTIL CURRENT IW MONTH & YEAR.

G65b BRANCHPOINT: IF R IS CURRENTLY SELF-EMPLOYED (G3=2), GO TO G67 BRANCHPOINT

G65b. Has your employer experienced a permanent reduction in employment since [MONTH, YEAR R STARTED CURRENT JOB (per G63/G63a)/R's LAST IW MONTH, YEAR/CURRENT IW MONTH, YEAR 2 YEARS AGO/you started working there]?

[IWER: PERMANENT EMPLOYMENT REDUCTIONS ARE SOMETIMES CALLED "DOWNSIZING"; "LAYOFFS" CAN BE PERMANENT OR TEMPORARY.]

1. YES	5. NO	8. DK	9. RF
GO TO G66			

G65c. Has this downsizing affected workers whose jobs are similar to yours?

1. YES	5. NO	8. DK	9. RF
--------	-------	-------	-------

G66. Are you covered by a union or employee-association contract?

1. YES	5. NO	8. DK	9. RF
--------	-------	-------	-------

G67 BRANCHPOINT: IF R WORKS FOR SAME EMPLOYER AS AT R's LAST IW (G19b=1) and WAS INCLUDED IN THAT EMPLOYER'S PENSION PLAN AT R's LAST IW, CONTINUE ON TO G67

IF R IS SELF-EMPLOYED NOW (G3=2) and WAS AT R's LAST IW and HAD A PENSION PLAN THEN and HAD THIS SAME JOB AT LAST IW (per G63/63a), CONTINUE ON TO G67

OTHERWISE, GO TO G75

G67. Have the rules that govern your pension benefits or the age you can receive them changed or has a new pension been offered to you by your firm since [CURRENT IW MONTH, YEAR 2 YEARS AGO/R's LAST IW MONTH, YEAR]?

1. YES	5. NO	7. DENIES BEING COVERED BY A PENSION	8. DK	9. RF
GO TO G76		GO TO G105 BRANCHPOINT		

G68. In how many different pension plans are you included on this job?

_____	0	DK	RF
NUMBER OF PLANS	GO TO G74e		GO TO G105 BRANCHPOINT

BEGINNING OF G69 LOOP: QUESTIONS G69 THROUGH G74d ARE REPEATED FOR UP TO FOUR PENSION PLANS.

G69. IF THIS IS THE FIRST PLAN AND R HAS MORE THAN ONE PLAN (G68 ≥ 2):
Now I have some questions about the most important of these plans.
I would like to know what type of plan this is.

IF THIS IS THE SECOND, THIRD OR FOURTH PLAN:
Now I have some questions about the next most important of these plans.
I would like to know what type of plan this is.

IF R HAS ONLY ONE PLAN (G68=1):
I would like to know what type of plan this is.

(In some retirement plans, Type A, benefits are usually based on a formula involving age, years of service and salary. In other plans, Type B, money is accumulated in an account for you.)

Is your plan Type A or Type B?

DEFINITION: 401-K, 403-B, ESOP, SRA, THRIFT/SAVINGS, STOCK/PROFIT SHARING, MONEY PURCHASE PLANS ARE ALL TYPE B RETIREMENT PLANS. TYPE A PLANS ARE OFTEN CALLED "DEFINED BENEFIT" PLANS; TYPE B PLANS ARE OFTEN CALLED "DEFINED CONTRIBUTION."

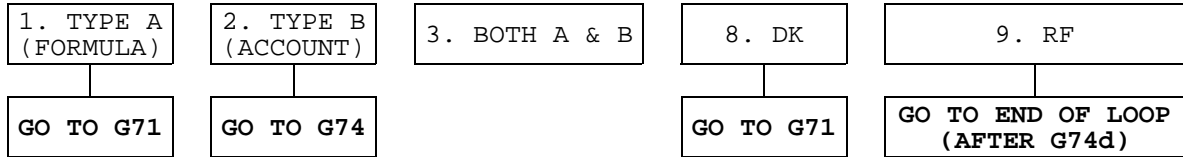

G70. For that part of your plan where money is accumulated in an account, how much is in the account at present?

AMOUNT

DK RF

G70a. Have you begun receiving benefits from this part of your pension?

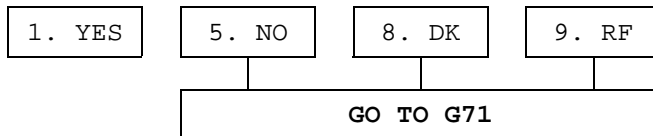

G70b. How much are you receiving?

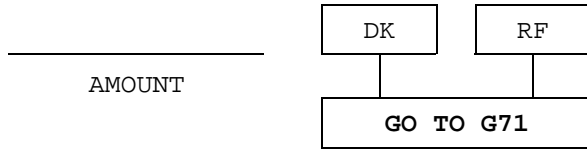

G70c. PER:

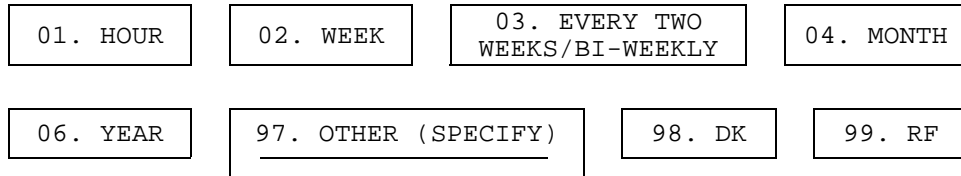

G71. IF R HAS BOTH TYPES OF PLAN (G69=3):
Now, about the part of your pension where benefits are based on a formula.

ASK ALL Rs:

At what age do you expect to start receiving benefits from this plan?

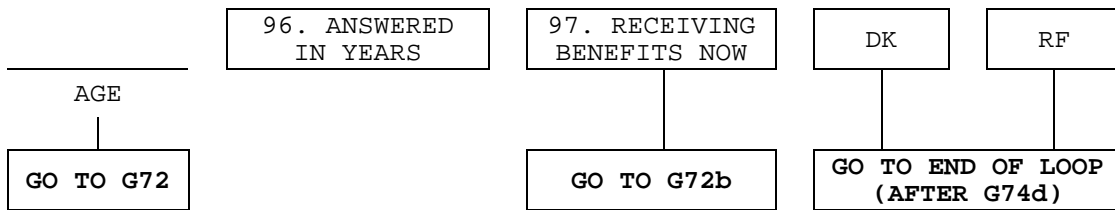

G71a. [IWER: "Expected age to start receiving benefits" IN YEARS]

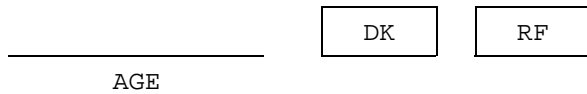

G72. About how much do you expect your benefits to be, either as a percent of your pay at retirement, or as an amount per month or year?

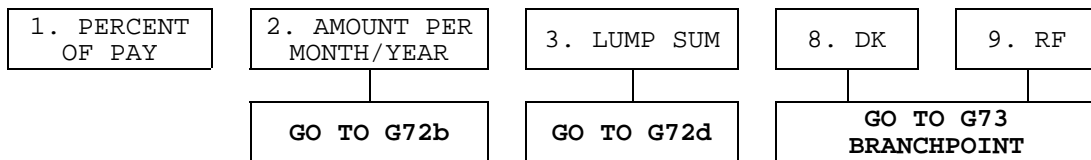

G72a. ENTER THE PERCENT OF FINAL PAY AT RETIREMENT:

PERCENT

DK RF

GO TO G73 BRANCHPOINT

G72b. [IWER: PROBE IF NECESSARY]
How much [are you receiving/do you expect to receive]?

[IWER: PROBE IF NECESSARY]
Was that per month or year?

AMOUNT

DK RF

GO TO G73 BRANCHPOINT

G72c. PER:

01. HOUR 02. WEEK 03. EVERY TWO WEEKS/BI-WEEKLY 04. MONTH

06. YEAR 97. OTHER (SPECIFY) 98. DK 99. RF

G72d BRANCHPOINT: IF R EXPECTS TO RECEIVE BENEFITS IN INSTALLMENTS (G72=2), GO TO G73 BRANCHPOINT

R IS ALREADY RECEIVING BENEFITS OF THIS PLAN (G71=97), GO TO END OF LOOP (AFTER G74d)

G72d. LUMP SUM AMOUNT:

AMOUNT

DK RF

G73 BRANCHPOINT: IF R WAS ALREADY ASKED G73 ABOUT ANOTHER PLAN, GO TO END OF LOOP (AFTER G74d)

G73. If you work [at this business/with this employer] [until AGE EXPECT BENEFITS (per G71)/for YEARS EXPECT BENEFITS (per G71a)], how much do you expect your pay to be?

[IWER: IF PER HOUR BE SURE TO ADD .00 FOR CENTS IF THERE ARE NONE]

[IWER: PROBE IF NECESSARY]

Was that per hour, week, month, or year?

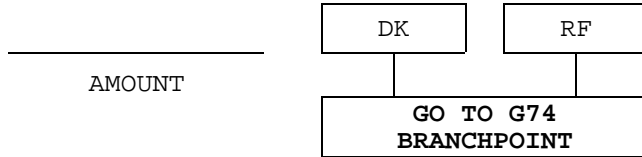

G73a. PER:

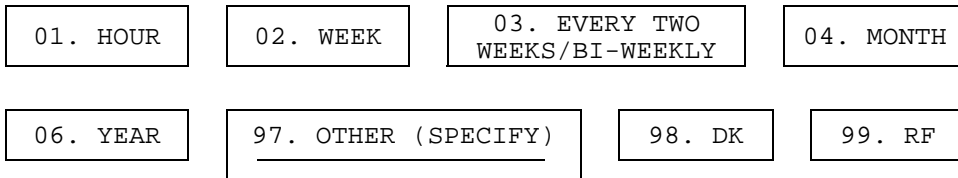

G74 BRANCHPOINT: IF THIS IS A {TYPE A or MIXED TYPE {A AND B}} PLAN (G69={1 or 3}), GO TO END OF LOOP (AFTER G74d)

G74b. Are you currently receiving benefits from this plan?

1. YES	5. NO	8. DK	9. RF
GO TO END OF LOOP (AFTER G74d)			

G74c. How much are you receiving?

_____	DK	RF
AMOUNT	GO TO END OF LOOP (AFTER G74d)	

G74d. PER:

01. HOUR	02. WEEK	03. EVERY TWO WEEKS/BI-WEEKLY	04. MONTH
06. YEAR	97. OTHER (SPECIFY) _____	98. DK	99. RF

END OF G69 LOOP: IF THERE ARE MORE PENSION PLANS GIVEN, REPEAT QUESTIONS G69 THROUGH G74d FOR UP TO FOUR PENSION PLANS. IF NOT, CONTINUE ON TO G74e BRANCHPOINT.

G74e BRANCHPOINT: IF R HAS {TYPE B or MIXED TYPE {A AND B}} PLAN (G69={2 or 3}), GO TO G105 BRANCHPOINT

IF R DID NOT REPORT THAT PENSION RULES HAD NOT CHANGED (G67 NOT 5), GO TO G75 BRANCHPOINT

G74e. Does your employer offer any kind of tax-deferred savings, 401K, or other such account plans for which you are eligible but choose not to participate in?

Please don't include IRA or KEOGH plans.

1. YES	5. NO	8. DK	9. RF
--------	-------	-------	-------

G75 BRANCHPOINT: IF R HAS AT LEAST ONE PENSION PLAN ON CURRENT JOB (G68 > 0), GO TO G105 BRANCHPOINT

G75. IF NOT SELF-EMPLOYED (G2 NOT 2):
 Now I'd like to ask about pension or retirement plans on your job, sponsored by your employer or union. This includes not only basic pension or retirement plans, but also tax-deferred plans like thrift, savings, 401k, deferred profit-sharing, or stock ownership plans.

Are you included in any such pension, retirement, or tax-deferred plan with this employer?

IF SELF-EMPLOYED (G2=2):
 Now I'd like to ask about pension or retirement plans on your job.

Aside from IRA or KEOGH plans, are you included in any pension plans or tax-deferred savings plans through your work?

[IWER: IF R MENTIONS IRA OR KEOGH PLANS, NOTE IN COMMENT BOX AND SAY:]
 "We will ask about these later in the interview. Here, I just want to find out about other plans operated through your [employer/business]."

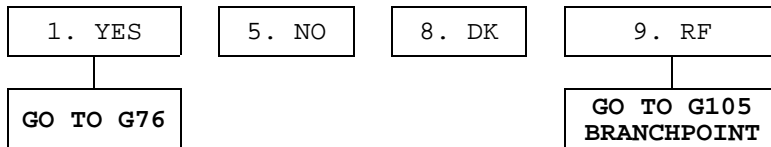

G75a BRANCHPOINT: IF R IS CURRENTLY SELF-EMPLOYED (G3=2), GO TO G105 BRANCHPOINT

G75a. Does your employer offer any such plans?

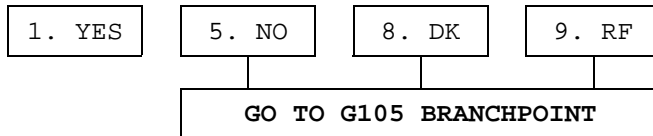

G75b. Are you eligible to be included in any of these plans?

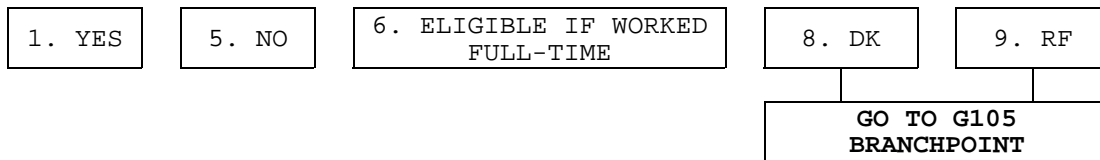

G75ba. What kind of plans are these?

In some retirement plans, Type A, benefits are usually based on a formula involving age, years of service and salary. In other plans, Type B, money is accumulated in an account for you.

Are these plans of Type A, Type B, or both?

DEFINITION: 401-K, 403-B, ESOP, SRA, THRIFT/SAVINGS, STOCK/PROFIT SHARING, MONEY PURCHASE PLANS ARE ALL TYPE B RETIREMENT PLANS. TYPE A PLANS ARE OFTEN CALLED "DEFINED BENEFIT" PLANS; TYPE B PLANS ARE OFTEN CALLED "DEFINED CONTRIBUTION."

- 1. TYPE A (FORMULA)
- 2. TYPE B (ACCOUNT)
- 3. BOTH A & B
- 8. DK
- 9. RF

G75bb BRANCHPOINT: IF R IS ELIGIBLE TO BE INCLUDED IN JOB'S RETIREMENT PLANS (G75b=1) and {IT IS TYPE A PLAN or DK or RF (G75ba={1 or DK or RF})}, GO TO G75d

IF R IS NOT ELIGIBLE TO BE INCLUDED IN JOB'S RETIREMENT PLANS (G75b=5) and {IT IS TYPE A PLAN or DK or RF (G75ba={1 or DK or RF})}, GO TO G75e

IF R IS ELIGIBLE TO BE INCLUDED IN JOB'S RETIREMENT PLANS ONLY IF WORKS FULL-TIME (G75b=6) and {IT IS TYPE A PLAN or DK or RF (G75ba={1 or DK or RF})}, GO TO G105 BRANCHPOINT

G75bb. (Could you tell me a little more about the account plan(s) offered by your employer?)

Do they include a thrift or savings plan, a 401K, a 403B, a Supplemental Retirement Account, a profit-sharing plan, a stock purchase plan, a money purchase plan, cash balance, or what?

[IWER: CHOOSE ALL THAT APPLY]

- 01. THRIFT OR SAVINGS
- 02. 401K
- 03. 403B
- 04. SUPPLEMENTAL RETIREMENT ACCOUNT
- 05. PROFIT SHARING
- 06. STOCK PURCHASE, ESOP
- 07. MONEY PURCHASE
- 08. CASH BALANCE
- 97. OTHER (SPECIFY)

- 98. DK
- 99. RF

G75c BRANCHPOINT: IF R IS NOT ELIGIBLE TO BE INCLUDED IN JOB'S RETIREMENT PLANS (G75b=5), GO TO G75e

IF R IS ELIGIBLE TO BE INCLUDED IN JOB'S RETIREMENT PLANS ONLY IF WORKS FULL-TIME (G75b=6), GO TO G105 BRANCHPOINT

IF R IS STILL WORKING FOR SAME EMPLOYER AS R'S LAST IW (G19b=1), GO TO G105 BRANCHPOINT

G75c. Does your employer make contributions to any such plans?

1. YES	5. NO	8. DK	9. RF
--------	-------	-------	-------

G75d. Do you intend to participate in any such plan at some time in the future?

1. YES	5. NO	8. DK	9. RF
GO TO G105 BRANCHPOINT			

G75e. Will you be eligible if you continue to work for this employer?

1. YES	3. DEPENDS (SPECIFY) _____	5. NO	8. DK	9. RF
GO TO G105 BRANCHPOINT				

G75f. How many more years will you have to work for this employer before you will be included in a pension plan?

_____	DK	RF
YEARS		
GO TO G105 BRANCHPOINT		

G76. IF PENSION PLAN HAS BEEN CHANGED (G67=1):
In how many different plans are you included on this job?

OTHERWISE:

In how many different plans (of this sort) are you included on this job

_____	DK	RF
NUMBER OF PLANS		
GO TO G105 BRANCHPOINT		

BEGINNING OF G77 LOOP: QUESTIONS G77 THROUGH G101c ARE ASKED FOR UP TO FOUR PENSION PLANS.

G77. IF THIS IS THE FIRST PLAN AND R HAS MORE THAN ONE PLAN (G76 ≥2):
Now I have some questions about the most important of these plans.
I would like to know what type of plan this is.

IF THIS IS THE SECOND, THIRD OR FOURTH PLAN:
Now I have some questions about the next most important of these plans.
I would like to know what type of plan this is.

IF R HAS ONLY ONE PLAN (G76=1):
I would like to know what type of plan this is.

(In some retirement plans, Type A, benefits are usually based on a formula involving age, years of service and salary. In other plans, Type B, money is accumulated in an account for you.)

Is your plan Type A or Type B?

DEFINITION: 401-K, 403-B, ESOP, SRA, THRIFT/SAVINGS, STOCK/PROFIT SHARING, MONEY PURCHASE PLANS ARE ALL TYPE B RETIREMENT PLANS. TYPE A PLANS ARE OFTEN CALLED "DEFINED BENEFIT" PLANS; TYPE B PLANS ARE OFTEN CALLED "DEFINED CONTRIBUTION."

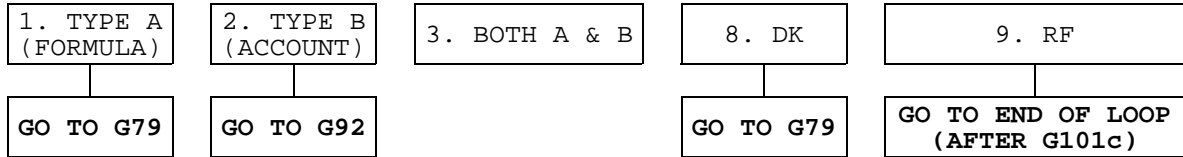

G78. For that part of your plan where money is accumulated in an account, how much is in the account at present?

	DK	RF
AMOUNT		
GO TO G79		

G78a. Did it amount to less than \$20,000, more than \$20,000, or what?	1. LESS THAN \$20,000	3. ABOUT \$20,000	5. MORE THAN \$20,000	8. DK	9. RF	
	GO TO G79		GO TO G79c		GO TO G79	
G78b. (Did it amount to) less than \$5,000, more than \$5,000, or what?	1. LESS THAN \$5,000	3. ABOUT \$5,000	5. MORE THAN \$5,000	8. DK	9. RF	
	GO TO G79					
G78c. (Did it amount to) less than \$50,000, more than \$50,000, or what?	1. LESS THAN \$50,000	3. ABOUT \$50,000	5. MORE THAN \$50,000	8. DK	9. RF	
	GO TO G79		GO TO G79			
G78d. (Did it amount to) less than \$150,000, more than \$150,000, or what?	1. LESS THAN \$150,000	3. ABOUT \$150,000	5. MORE THAN \$150,000	8. DK	9. RF	

G79. How much do you currently contribute, either as a percent of your pay or as an amount of money per month or year?

[IWER: INCLUDE CONTRIBUTIONS THROUGH SALARY DEDUCTIONS, UNION DUES OR OTHER SOURCES]

1. PERCENT OF PAY	2. AMOUNT OF MONEY PER MONTH/YEAR	6. DOESN'T CONTRIBUTE ANYTHING	8. DK	9. RF
	GO TO G79b	GO TO G80		

G79a. ENTER PERCENT OF THE PAY:

PERCENT	DK	RF
	GO TO G80	

G79b. [IWER: PROBE IF NECESSARY]
How much do you currently contribute?

[IWER: PROBE IF NECESSARY]
Was that per month or year?

AMOUNT	DK	RF
	GO TO G80	

G79c. PER:

01. HOUR	02. WEEK	03. EVERY TWO WEEKS/BI-WEEKLY	04. MONTH
06. YEAR	97. OTHER (SPECIFY)	98. DK	99. RF

G80. (Now, about the part of your pension where benefits are based on a formula.)

For how many years altogether have you been included in this plan?

[IWER: INCLUDE YEARS WITH OTHER EMPLOYERS IF SAME PLAN]

0-50 YEARS IN PLAN

YEARS IN PLAN	DK	RF
---------------	----	----

G81. At what age do you expect to start receiving benefits from this plan?

	96. ANSWER IN YEARS	97. RECEIVING BENEFITS NOW	DK	RF
AGE				
GO TO G82		GO TO G82b	GO TO G83	

G81a. [IWER: "Expected age to start receiving benefits" IN YEARS]

	DK	RF
YEARS		

G82. About how much do you expect your benefits to be, either as a percent of your pay at retirement, or as an amount per month or year?

1. PERCENT OF PAY	2. AMOUNT PER MONTH/YEAR	3. LUMP SUM	8. DK	9. RF
	GO TO G82b	GO TO G82d	GO TO G83	

G82a. ENTER PERCENT OF FINAL PAY AT RETIREMENT:

	DK	RF
PERCENT		
GO TO G83		

G82b. IF R IS ALREADY RECEIVING BENEFITS (G81=97):
How much are you receiving?

OTHERWISE:
How much do you expect to receive?

[IWER: PROBE IF NECESSARY]
Was that per month or year?

	DK	RF
AMOUNT		
GO TO G83		

G82c. PER:

01. HOUR	02. WEEK	03. EVERY TWO WEEKS/BI-WEEKLY	04. MONTH
06. YEAR	97. OTHER (SPECIFY) _____	98. DK	99. RF

G82d BRANCHPOINT: GO TO G83

G82d. LUMP SUM AMOUNT:

AMOUNT

DK

RF

G83. (Most pension plans have a normal retirement age at which full benefits — sometimes called unreduced benefits — can be received. Some plans allow retirement at an earlier age, usually with reduced benefits. And in many plans, normal retirement age depends on years of service.)

What is the earliest age at which you would be eligible to receive full or unreduced pension benefits from this plan?

[IWER: IF R REPORTS THAT S/HE IS ALREADY ELIGIBLE, ASK:]
 What is the earliest age at which you would have been eligible (to receive full or unreduced pension benefits from this plan)?

AGE

95. ANY TIME; NO AGE REQUIREMENT; ANY AGE

DK

RF

GO TO G89

GO TO G86

G84 BRANCHPOINT: IF AGE R IS ELIGIBLE FOR BENEFITS (per G83) IS SAME AS AGE R EXPECTS BENEFITS (per G81), GO TO G85 BRANCHPOINT

G84. How much would these full or unreduced benefits be, either as a percent of your pay at retirement, or as an amount per month or year?

1. PERCENT OF PAY

2. AMOUNT PER MONTH/YEAR

3. LUMP SUM

8. DK

9. RF

GO TO G84b

GO TO G84d

GO TO G85 BRANCHPOINT

G84a. ENTER PERCENT OF FINAL PAY AT RETIREMENT:

PERCENT

DK

RF

GO TO G85 BRANCHPOINT

G84b. [IWER: PROBE IF NECESSARY]
How much would you receive?

[IWER: PROBE IF NECESSARY]
Is that per month or year?

AMOUNT

DK	RF
----	----

GO TO G85
BRANCHPOINT

G84c. PER:

01. HOUR	02. WEEK	03. EVERY TWO WEEKS/BI-WEEKLY	04. MONTH
----------	----------	----------------------------------	-----------

GO TO G85 BRANCHPOINT

06. YEAR	97. OTHER (SPECIFY) _____	98. DK	99. RF
----------	------------------------------	--------	--------

GO TO G85 BRANCHPOINT

G84d. LUMP SUM AMOUNT:

AMOUNT

DK	RF
----	----

G85 BRANCHPOINT: IF R WAS ALREADY ASKED G85 FOR ANOTHER PLAN, GO TO G86

G85. If you work [at this business/with this employer] until *AGE ELIGIBLE FOR PENSION* (per G83), how much do you expect your pay to be?

[IWER: IF PER HOUR BE SURE TO ADD .00 FOR CENTS IF THERE ARE NONE]

[IWER: PROBE IF NECESSARY]
Was that per week, month, or year?

_____	DK	RF
AMOUNT		
GO TO G86		

G85a. PER:

01. HOUR	02. WEEK	03. EVERY TWO WEEKS/BI-WEEKLY	04. MONTH
06. YEAR	97. OTHER (SPECIFY) _____	98. DK	99. RF

G86. What is the earliest age at which you could leave this [business/employer] and start to receive pension benefits from this plan?

[IWER: IF R REPORTS THAT S/HE IS ALREADY ELIGIBLE, ASK:]
What is the earliest age at which you could have done so (that is, started to receive benefits from this plan)?

_____	95. ANY TIME; NO AGE REQUIREMENT; ANY AGE	DK	RF
AGE			
GO TO G89			

G88 BRANCHPOINT: IF EARLIEST AGE R COULD {LEAVE JOB AND RECEIVE PENSION BENEFITS} (per G86) IS SAME AS {EARLIEST AGE R COULD RECEIVE FULL PENSION (per G83) or AGE R EXPECTS TO RECEIVE BENEFITS (per G81)}, GO TO G89

G88. By how much would your pension be reduced from full benefits if you left this job at *EARLIEST AGE TO RECEIVE PENSION* (per G86)?

1. PERCENT OF BENEFITS	2. AMOUNT PER MONTH/YEAR	3. LUMP SUM	6. BENEFITS WOULD NOT BE REDUCED	8. DK	9. RF
GO TO G88b		GO TO G88d	GO TO G89		

G88a. ENTER PERCENT BY WHICH FULL BENEFITS ARE REDUCED:

IF R ANSWERED {G84=1 and G88=1}, BOTH AS PERCENTS:
[IWER: CONFIRM THAT R MEANS % OF PENSION BENEFITS (NOT PERCENT OF SALARY)]

PERCENT

DK RF

GO TO G89

G88b. [IWER: PROBE IF NECESSARY]
How much would your benefits be reduced?

[IWER: PROBE IF NECESSARY]
Was that per month or year?

AMOUNT

DK RF

GO TO G89

G88c. PER:

01. HOUR 02. WEEK 03. EVERY TWO WEEKS/BI-WEEKLY 04. MONTH

06. YEAR 97. OTHER (SPECIFY) 98. DK 99. RF

G88d BRANCHPOINT: GO TO G89

G88d. LUMP SUM AMOUNT:

AMOUNT

DK RF

G89. Does the amount of your pension from this plan depend on Social Security benefits, in that when you start receiving Social Security benefits your pension benefits will be reduced?

1. YES 5. NO 8. DK 9. RF

GO TO G90 BRANCHPOINT

G89a. When will this change take place: automatically at age 62, automatically at age 65, when you start receiving Social Security benefits, or at some other time?

1. AT AGE 62	2. AT AGE 65	3. WHEN SOCIAL SECURITY BENEFITS BEGIN	4. AT SOME OTHER TIME	8. DK	9. RF
-----------------	-----------------	--	--------------------------	-------	-------

G90 BRANCHPOINT: IF R EXPECTS TO RECEIVE A LUMP SUM PAYMENT (G82=3), GO TO END OF G77 LOOP (AFTER G101c)

G90. Rather than regular retirement benefits, could you choose to receive a lump-sum settlement from this plan when you retire?

1. YES	2. YES, PARTIAL LUMP SUM	5. NO	8. DK	9. RF
--------	--------------------------	-------	-------	-------

G92 BRANCHPOINT: GO TO END OF G77 LOOP (AFTER G101c)

G92. (Could you tell me a little more about this plan?)

Is it a thrift or savings plan, a 401K, a 403B, a Supplemental Retirement Account, a profit-sharing plan, a stock purchase plan, a money purchase plan, a cash balance plan, or what?

01. THRIFT OR SAVINGS	02. 401K	03. 403B	04. SUPPLEMENTAL RETIREMENT ACCOUNT	05. PROFIT SHARING	
06. STOCK PURCHASE, ESOP	07. MONEY PURCHASE	08. CASH BALANCE	97. OTHER (SPECIFY) _____	98. DK	99. RF

G93. For how many years altogether have you been included in this plan?

[IWER: INCLUDE YEARS WITH OTHER EMPLOYERS, IF SAME PLAN]

DK	RF
----	----

YEARS WITH PLAN

G94. How much does your [business/employer] contribute, either as a percent of your pay or as an amount of money per month or year?

1. PERCENT OF PAY	2. AMOUNT OF MONEY PER MONTH/YEAR	6. DOESN'T CONTRIBUTE ANYTHING	8. DK	9. RF
	GO TO G94b	GO TO G95		

G94a. ENTER PERCENT OF PAY:

	DK	RF
PERCENT		
GO TO G95		

G94b. ENTER EMPLOYER CONTRIBUTED AMOUNT:

[IWER: PROBE IF NECESSARY]
Was that per month or year?

	DK	RF
AMOUNT		
GO TO G95		

G94c. PER:

01. HOUR	02. WEEK	03. EVERY TWO WEEKS/BI-WEEKLY	04. MONTH
06. YEAR	97. OTHER (SPECIFY) _____	98. DK	99. RF

G95. How much do you currently contribute to this plan, that is, what is the sum of any amount that you are required to contribute plus any amount that you voluntarily contribute?

1. PERCENT OF PAY	2. AMOUNT OF MONEY PER MONTH/YEAR	6. DOESN'T CONTRIBUTE ANYTHING	8. DK	9. RF
	GO TO G95b	GO TO G96		

G95a. ENTER PERCENT OF PAY:

	DK	RF
PERCENT		
GO TO G95d BRANCHPOINT		

G95b. [IWER: PROBE IF NECESSARY]
How much do you contribute?

[IWER: PROBE IF NECESSARY]
Was that per month or year?

AMOUNT

DK	RF
GO TO G95d BRANCHPOINT	

G95c. PER:

01. HOUR	02. WEEK	03. EVERY TWO WEEKS/BI-WEEKLY	04. MONTH
06. YEAR	97. OTHER (SPECIFY) _____	98. DK	99. RF

G95d BRANCHPOINT: IF R DID NOT REPORT THAT {S/HE or EMPLOYER} CONTRIBUTES ANYTHING TO PENSION PLAN ({G94 or G95}={6 or DK or RF}), GO TO G96

G95d. If you wanted to reduce your contribution as low as possible while still having your [business/employer] contribute something to the plan, how far could you reduce it?

[IWER: ENTER MINIMUM PERCENT OF PAY THAT R CAN CONTRIBUTE BEFORE EMPLOYER/BUSINESS WOULD STOP MAKING ANY CONTRIBUTION]

[IWER: ENTER 0 IF EMPLOYER/BUSINESS WOULD MAKE CONTRIBUTION EVEN IF RESPONDENT MADE NO CONTRIBUTION]

[IWER: ENTER 95 IF RESPONDENT COULD NOT REDUCE HIS/HER CONTRIBUTION]

[IWER: IF RESPONDENT GIVES DOLLAR AMOUNT, ENTER ALT-D AND USE F2 COMMENT]

MINIMUM PERCENT

DK	RF
----	----

HRS 2000 — SECTION G: EMPLOYMENT — PAGE 359

FINAL VERSION 3 — 8/13/2002

G98. Is the money in this account invested mostly in stocks, mostly in interest earning assets, is it about evenly split between these, or what?

1. MOSTLY OR ALL STOCK	2. MOSTLY OR ALL INTEREST EARNING	3. SPLIT	7. OTHER (SPECIFY) _____	8. DK	9. RF
------------------------------	--	----------	--------------------------------	-------	-------

G99. Does this plan allow you to receive benefits in the form of one or more lump sum payments?

1. YES	2. YES, PARTIAL LUMP SUM	5. NO	8. DK	9. RF
GO TO G100a				

G100. Does it allow you to receive benefits in the form of installments or a monthly pension?

1. YES	5. NO	8. DK	9. RF
GO TO G100b		GO TO G101	

G100a. What is the youngest age at which you could [stop working at this business/leave this employer] and start receiving a monthly pension or installments from this plan?

_____	95. ANY TIME; NO AGE REQUIREMENT; ANY AGE	DK	RF
AGE	GO TO G101		

G100b. What is the youngest age at which you could [stop working at this business/leave this employer] and receive a lump sum payment from this plan?

_____	95. ANY TIME; NO AGE REQUIREMENT; ANY AGE	DK	RF
AGE			

G101. At what age do you expect to start receiving any benefits from this plan?

_____	95. RECEIVING BENEFITS NOW	DK	RF
AGE	GO TO G101b		

G101a BRANCHPOINT: IF R'S PLAN ALLOWS A LUMP SUM PAYMENT (G99=1) and NOT INSTALLMENTS (G100=5) and R EXPECTS TO RECEIVE BENEFITS IN THE FUTURE (G101 AGE={35-94}), GO TO END OF G77 LOOP (AFTER G101c)

IF R'S PLAN {ALLOWS A LUMP SUM PAYMENT (G99=1) and DOES NOT ALLOW PAYMENT IN INSTALLMENTS (G100=5)}, GO TO G101b BRANCHPOINT

G101a. In what form do you expect to receive benefits?

(As one or more lump sum payments, as a monthly pension, as installments, or what?)

1. LUMP SUM PAYMENT(S)	2. MONTHLY PENSION	3. INSTALLMENTS	7. OTHER (SPECIFY) _____	8. DK	9. RF
GO TO END OF LOOP (AFTER G101c)					

NOTE: INTERVIEWERS COULD CHOOSE ALL OF THE RESPONSES, ABOVE, THAT APPLIED.

G101b BRANCHPOINT: IF R DID NOT REPORT RECEIVING BENEFITS NOW (G101 NOT 95), GO TO END OF G77 LOOP (AFTER G101c)

G101b. How much are you receiving?

_____	DK	RF
AMOUNT	GO TO END OF LOOP (AFTER G101c)	

G101c. PER:

01. HOUR	02. WEEK	03. EVERY TWO WEEKS/BI-WEEKLY	04. MONTH
06. YEAR	97. OTHER (SPECIFY) _____	98. DK	99. RF

END OF G77 LOOP: IF THERE ARE MORE PENSION PLANS GIVEN, REPEAT QUESTIONS G77 THROUGH G101c FOR UP TO FOUR PENSION PLANS. IF NOT, CONTINUE ON TO G103 BRANCHPOINT.

G103 BRANCHPOINT: IF R HAS FEWER THAN 5 PLANS (G76 < 5), GO TO G104 BRANCHPOINT

G103. Altogether how much do you have in your account balance(s) for any other pension plans or savings plan(s) from this job?

AMOUNT

G104 BRANCHPOINT: IF R HAS {TYPE B or MIXED TYPE {A AND B}} PLAN (G77={2 or 3}), GO TO G105 BRANCHPOINT

G104. Does your [business/employer] offer any kind of tax-deferred savings, 401K, or other such account plans for which you are eligible but choose not to participate in?

Please don't include IRA or KEOGH plans.

G105 BRANCHPOINT: IF THIS IS A PROXY INTERVIEW, GO TO G128

IF R HAS SAME JOB TITLE AS LAST IW (G21=1) or {IF R IS CURRENTLY SELF-EMPLOYED (G3=2) and R WAS SELF-EMPLOYED AT LAST IW and THE {MONTH AND YEAR} GIVEN THAT S/HE STARTED WORKING AT CURRENT JOB {per G63/G63a} IS {ON OR BEFORE} THE {MONTH AND YEAR} S/HE GAVE AT LAST IW}, GO TO G109

G105. Counting high school graduation as 12 years, about how many years of school would you say are needed to do your job reasonably well?

NUMBER OF YEARS

GO TO G109

G105a. (For someone with this much formal schooling,) About how much experience do you think it would take to become good at your job?

AMOUNT OF EXPERIENCE

GO TO G109

G105b. UNIT:

G109. Sometimes people look for a different job even when they are currently working. Are you currently looking for another job?

1. YES	5. NO	8. DK	9. RF
GO TO G114			

G110. Are you looking for jobs only in this area, or are you considering jobs that would require you to move?

1. JOBS IN THIS AREA	2. JOBS REQUIRING A MOVE	3. BOTH/ EITHER ONE	8. DK	9. RF
----------------------	--------------------------	---------------------	-------	-------

G111. Are you looking for part-time or full-time work?

1. PART-TIME	2. FULL-TIME	3. EITHER KIND	8. DK	9. RF
--------------	--------------	----------------	-------	-------

G112. Are you looking for the same kind of work you're doing now, or something different?

1. SAME	2. EITHER/BOTH	3. DIFFERENT	8. DK	9. RF
GO TO G113			GO TO G113	

G112a. How would it be different?

DK	RF
----	----

G113. During the past four weeks, what have you been doing to find another job?

[IWER: DO NOT READ CATEGORIES. CHOOSE ALL THAT APPLY.]

01. CHECKED WITH PUBLIC EMPLOYMENT AGENCY	02. CHECKED WITH PRIVATE EMPLOYMENT AGENCY	03. VISITED EMPLOYERS DIRECTLY	04. TELEPHONED OR WROTE EMPLOYERS DIRECTLY
05. ASKED FRIENDS OR RELATIVES	06. PLACED OR ANSWERED ADS	07. READ ADS	08. DIDN'T DO ANYTHING SPECIFIC
97. OTHER (SPECIFY) _____		98. DK	99. RF

G113e1 BRANCHPOINT: IF R DID NOT VISIT EMPLOYERS DIRECTLY (G113 NOT 3), GO TO G113f1 BRANCHPOINT

G113e1. How many employers did you visit?

NUMBER OF EMPLOYERS

DK

RF

G113f1 BRANCHPOINT: IF R DID NOT {TELEPHONE OR WRITE} EMPLOYERS DIRECTLY (G113 NOT 4), GO TO G114 BRANCHPOINT

G113f1. How many employers did you call or write?

NUMBER OF EMPLOYERS

DK

RF

G114 BRANCHPOINT: IF R WAS ASKED WHAT S/HE WAS DOING TO FIND ANOTHER JOB AT G113, GO TO G115 BRANCHPOINT

G114. If you found out about another job like the one you have now, would you look into it?

1. YES

2. PROBABLY

3. MAYBE

4. PROBABLY NOT

5. NO

7. OTHER (SPECIFY)

8. DK

9. RF

G115 BRANCHPOINT: IF R HAS SAME JOB TITLE AS LAST IW (G21=1) or R {IS SELF-EMPLOYED (G3=2) and WAS SELF-EMPLOYED AT R's LAST IW}, GO TO G127

OTHERWISE, GO TO G126

G115. Have you been doing anything to find work during the last four weeks?

1. YES

5. NO

8. DK

9. RF

GO TO G119

G116. Are you looking for part-time or full-time work?

1. PART-TIME

2. FULL-TIME

3. EITHER KIND

8. DK

9. RF

G117. Are you looking for the same kind of work you did before, or something different?

1. SAME	2. DIFFERENT	3. EITHER OR BOTH	8. DK	9. RF
GO TO G117b	GO TO G117b			

G117a. How would it be different?

DK	RF
----	----

G117b. If you were to be offered work like that, how high would the wage or salary have to be for you to take it?

[IWER: IF PER HOUR BE SURE TO ADD .00 FOR CENTS IF THERE ARE NONE]

[IWER: PROBE IF NECESSARY]
Is that per hour, week, month, or year?

AMOUNT

DK	RF
GO TO G118	

G117Y1b. PER:

01. HOUR	02. WEEK	03. EVERY TWO WEEKS/BI-WEEKLY	04. MONTH
06. YEAR	97. OTHER (SPECIFY) _____	98. DK	99. RF

G118. What are all of the things you have done to find work during the last four weeks?

[IWER: DO NOT READ CATEGORIES. CHOOSE ALL THAT APPLY.]

01. READ ADS	02. ATTEND SCHOOL OR RECEIVED OTHER TRAINING	03. CHECKED WITH PUBLIC EMPLOYMENT AGENCY	04. CHECK WITH PRIVATE EMPLOYMENT AGENCY
05. VISITED EMPLOYERS DIRECTLY	06. TELEPHONED OR WROTE EMPLOYERS DIRECTLY	07. ASKED FRIENDS OR RELATIVES	08. PLACED OR ANSWERED ADS
96. DIDN'T DO ANYTHING SPECIFIC	97. OTHER (SPECIFY) _____	98. DK	99. RF

GO TO G121

G118e1/f1 BRANCHPOINT: IF R {DID NOT VISIT *and* DID NOT TELEPHONE} ANY EMPLOYERS DIRECTLY (G118 {NOT 5 *and* NOT 6}), GO TO G134

G118e1/f1. How many employers did you [visit/call or write/visit, call, or write]?

NUMBER OF EMPLOYERS VISITED	NUMBER OF EMPLOYERS CALLED OR WRITTEN	DK	RF
GO TO G134			

G119. Do you currently want a job, either full-time or part-time?

1. YES	3. DEPENDS	5. NO	6. CAN'T WORK	8. DK	9. RF
GO TO G134					

G119a. Would you prefer part-time or full-time?

1. PART-TIME	2. FULL-TIME	3. EITHER	8. DK	9. RF
--------------	--------------	-----------	-------	-------

G120. If someone offered you a regular job now, how high would the wage or salary have to be for you to take it?

[IWER: IF PER HOUR BE SURE TO ADD .00 FOR CENTS IF THERE ARE NONE]

[IWER: PROBE IF NECESSARY]

Is that per hour, week, month, or year?

_____	DK	RF
AMOUNT		
	GO TO G121	

G120a. PER:

01. HOUR	02. WEEK	03. EVERY TWO WEEKS/BI-WEEKLY	04. MONTH
06. YEAR	97. OTHER (SPECIFY) _____	98. DK	99. RF

G121. What is the main reason you were not looking for work during the last four weeks?

[IWER: DO NOT READ CATEGORIES]

01. BELIEVES NOTHING AVAILABLE IN LINE OF WORK	02. DOESN'T BELIEVE CAN FIND WORK	03. DOESN'T HAVE NEEDED SKILLS/EXPERIENCE	04. BELIEVES EMPLOYERS THINK TOO OLD
05. BELIEVES EMPLOYERS WON'T HIRE OLDER WOMEN MINORITIES	06. POOR HEALTH, DISABILITY	07. FAMILY RESPONSIBILITIES /CHILD RESPONSIBILITIES	08. TRANSPORTATION PROBLEMS
95. NO PARTICULAR REASON	97. OTHER (SPECIFY) _____	98. DK	99. RF

G126 BRANCHPOINT: IF R WAS ASKED G121, GO TO G134

HRS 2000 — SECTION G: EMPLOYMENT — PAGE 367

FINAL VERSION 3 — 8/13/2002

G126. I'll read some statements that are true for some people's jobs but not for other people's jobs. Thinking of your job, please tell me how often these statements are true.

	1. ALL OR ALMOST ALL OF THE TIME	2. MOST OF THE TIME	3. SOME OF THE TIME	4. NONE OR ALMOST NONE OF THE TIME	8. DK	9. RF
G126a. My job requires lots of physical effort. Is this true all or almost all of the time, most of the time, some of the time, or none or almost none of the time?						
G126b. (My job requires) lifting heavy loads. (Is this true all or almost all of the time, most of the time, some of the time, or none or almost none of the time?)						
G126c. (My job requires) stooping, kneeling, or crouching. (Is this true all or almost all of the time, most of the time, some of the time, or none or almost none of the time?)						
G126d. My job requires good eyesight. (Is this true all or almost all of the time, most of the time, some of the time, or none or almost none of the time?)						
G126e. (My job requires) intense concentration or attention. (Is this true all or almost all of the time, most of the time, some of the time, or none or almost none of the time?)						
G126f. (My job requires) skill in dealing with other people. (Is this true all or almost all of the time, most of the time, some of the time, or none or almost none of the time?)						
G126g. (My job requires) me to work with computers. (Is this true all or almost all of the time, most of the time, some of the time, or none or almost none of the time?)						

G127. Here are some (more) statements that are true for some people's jobs but not for others. (Again) Thinking of your job, [please/this time] indicate how much you agree or disagree with each statement.

	1. STRONGLY AGREE	2. AGREE	3. DISAGREE	4. STRONGLY DISAGREE	8. DK	9. RF
G127a. My job requires me to do more difficult things than it used to. Do you strongly agree, agree, disagree or strongly disagree with that statement?						
G127b. My job involves a lot of stress. (Do you strongly agree, agree, disagree or strongly disagree with that statement?)						

G127c BRANCHPOINT: IF R IS SELF-EMPLOYED (G3=2), GO TO G127e

	1. STRONGLY AGREE	2. AGREE	3. DISAGREE	4. STRONGLY DISAGREE	8. DK	9. RF
G127c. In decisions about promotion, my employer gives younger people preference over older people. (Do you strongly agree, agree, disagree or strongly disagree with that statement?)						
G127d. My co-workers make older workers feel that they ought to retire before age 65. (Do you strongly agree, agree, disagree or strongly disagree with that statement?)						
G127e. As I get older, I would prefer to gradually reduce the hours I work on this job, keeping my pay per hour the same. (Do you strongly agree, agree, disagree or strongly disagree with that statement?)						

G127f BRANCHPOINT: IF R IS SELF-EMPLOYED (G3=2), GO TO G127g

	1. STRONGLY AGREE	2. AGREE	3. DISAGREE	4. STRONGLY DISAGREE	8. DK	9. RF
G127f. My employer would let older workers move to a less demanding job with less pay if they wanted to. (Do you strongly agree, agree, disagree or strongly disagree with that statement?)						
G127g. I really enjoy going to work. (Do you strongly agree, agree, disagree or strongly disagree with that statement?)						

G128. Are you doing any other work for pay now, such as (another) business of your own, a second job or the military reserves?

1. YES	5. NO	8. DK	9. RF
GO TO G132			

G128a. Is this your own business, a second job, the military reserves, or what?

[IWER: CHOOSE ALL THAT APPLY]

1. OWN BUSINESS	2. SECOND JOB	3. MILITARY RESERVES	7. OTHER (SPECIFY) _____	8. DK	9. RF
-----------------	---------------	----------------------	-----------------------------	-------	-------

G129. How many hours a week do you usually work on [this other job/these other jobs]?

_____ HOURS

DK	RF
----	----

G130. Counting paid vacations as weeks of work, how many weeks a year do you usually work on (this other job/these other jobs)?

_____ WEEKS

DK	RF
----	----

G131. About how much do you earn before taxes from [this other job/these other jobs]?

[IWER: IF PER HOUR BE SURE TO ADD .00 FOR CENTS IF THERE ARE NONE]

[IWER: PROBE IF NECESSARY]

Is that per hour, week, month, year, or what?

AMOUNT

DK	RF
----	----

GO TO G132

G131a. PER:

01. HOUR	02. WEEK	03. EVERY TWO WEEKS/BI-WEEKLY	04. MONTH
06. YEAR	97. OTHER (SPECIFY) _____	98. DK	99. RF

G132. Now I have a few questions about work and retirement.

On your main job, what is the usual retirement age for people who work with you or have the same kind of job?

YEARS OF AGE

95. NO "USUAL"	96. ANSWER IN YEARS OF SERVICE	DK	RF
----------------	--------------------------------	----	----

GO TO G133 BRANCHPOINT

GO TO G133 BRANCHPOINT

G132a. ENTER USUAL NUMBER OF YEARS OF SERVICE:

YEARS OF SERVICE

DK	RF
----	----

G133 BRANCHPOINT: IF THIS IS A PROXY INTERVIEW, GO TO G141 BRANCHPOINT

G133. Now I want to ask about your retirement plans.

Do you plan to stop working altogether or reduce work hours at a particular date or age, have you not given it much thought, or what?

[IWER: DO NOT PROBE BUT CHOOSE ALL THAT APPLY AND ASK ALL FOLLOW-UP QUESTIONS.]

01. STOP WORK ALTOGETHER	02. NEVER STOP WORK	03. NOT GIVEN MUCH THOUGHT	04. NO CURRENT PLANS, CONTINUE AS IS
05. REDUCE WORK HOURS	06. CHANGE KIND OF WORK	07. WORK FOR MYSELF	08. WORK UNTIL MY HEALTH FAILS
97. OTHER (SPECIFY) _____		98. DK	99. RF

G133a BRANCHPOINT: IF R PLANS TO STOP WORKING ALTOGETHER (G133=1),
CONTINUE ON TO G133a
OTHERWISE, GO TO G133b BRANCHPOINT

G133a. At what age do you plan to stop working?

_____	95. NEVER	96. ANSWERED IN YEAR THAT WILL STOP WORKING	DK	RF
YEARS OF AGE				
	GO TO G133b BRANCHPOINT		GO TO G133b BRANCHPOINT	

G133a1. ENTER YEAR PLANNING TO STOP WORKING:

_____	9995. NEVER	DK	RF
YEAR			
	GO TO G133c BRANCHPOINT		

G133b BRANCHPOINT: IF R SAID {HAD NOT GIVEN MUCH THOUGHT or HAD NO CURRENT}
RETIREMENT PLANS (G133={3 or 4}), CONTINUE ON TO G133b
OTHERWISE, GO TO G133c BRANCHPOINT

G133b. At what age do you think you will stop working?

_____	95. NEVER	96. ANSWERED IN YEAR THAT WILL STOP WORKING	DK	RF
YEARS OF AGE				
	GO TO G133c BRANCHPOINT		GO TO G133c BRANCHPOINT	

G133b1. ENTER YEAR THINKING TO STOP WORKING:

_____	9995. NEVER	DK	RF
YEAR PLANNING TO STOP WORKING			

G133c BRANCHPOINT: IF R DID NOT SAY S/HE PLANS TO REDUCE WORK HOURS (G133 NOT 5), GO TO G133d BRANCHPOINT

G133c. At what age do you plan to start working fewer hours?

_____	95. NEVER	96. YEAR PLANNING TO START WORKING FEWER HOURS	DK	RF
YEARS OF AGE				
	GO TO G133d BRANCHPOINT		GO TO G133d BRANCHPOINT	

G133c1. ENTER YEAR PLANNING TO START WORKING FEWER HOURS:

_____	DK	RF
YEAR PLANNING TO START WORKING FEWER HOURS		

G133d BRANCHPOINT: IF R DID NOT SAY S/HE PLANS TO CHANGE KIND OF WORK (G133 NOT 6), GO TO G133e BRANCHPOINT

G133d. At what age do you plan to change the kind of work you do?

_____	95. NEVER	96. YEAR PLANNING TO CHANGE WORK	DK	RF
YEARS OF AGE				
	GO TO G133e BRANCHPOINT		GO TO G133e BRANCHPOINT	

G133d1. ENTER YEAR PLANNING TO CHANGE WORK:

_____	DK	RF
YEAR PLANNING TO CHANGE WORK		

G133e BRANCHPOINT: IF R DOES NOT PLAN TO WORK FOR HIM/HERSELF (G133 NOT 7),
GO TO G134

G133e. At what age do you plan to start working for yourself?

_____	95. NEVER	96. YEAR PLANNING SELF-EMPLOYMENT	DK	RF
YEARS OF AGE				
	GO TO G134		GO TO G134	GO TO G134

G133e1. ENTER YEAR PLANNING TO START SELF-EMPLOYMENT:

_____	DK	RF
YEAR STARTING SELF EMPLOYMENT		

G134. We are interested in what people think about retirement, whether they themselves are retired or not.

At this time do you consider yourself partly retired, completely retired, or not retired at all?

1. COMPLETELY RETIRED	3. PARTLY RETIRED	5. NOT RETIRED AT ALL
		GO TO G139 BRANCHPOINT
7. QUESTION NOT RELEVANT TO R, DOESN'T WORK FOR PAY OR IS HOMEMAKER, ETC.		8. DK
GO TO G141 BRANCHPOINT		9. RF

G134a BRANCHPOINT: IF R IS COMPLETELY RETIRED NOW (G134=1) *and* WAS COMPLETELY RETIRED AT R's LAST IW, GO TO G136

IF R IS PARTLY RETIRED (G134=3) *and* WAS PARTLY RETIRED AT R's LAST IW, GO TO G139 BRANCHPOINT

IF R GAVE YEAR S/HE RETIRED AT G1j, GO TO G135

G134a. In what month and year did you [partly/completely] retire?

[IWER: MONTHS ENTERED MUST BE BEFORE CURRENT IW MONTH, YEAR]

G134a. MONTH:

01. JAN	02. FEB	03. MAR	04. APR	05. MAY	06. JUN	07. JUL
08. AUG	09. SEP	10. OCT	11. NOV	12. DEC	98. DK	99. RF
_____		DK	RF			

G134Y1a. YEAR

G135. Thinking back to the time you [partly/completely] retired, was that something you wanted to do or something you felt you were forced into?

1. WANTED TO DO	2. FORCED INTO	3. PART WANTED, PART FORCED	8. DK	9. RF
-----------------	----------------	-----------------------------	-------	-------

G136 BRANCHPOINT: IF R IS NOT COMPLETELY RETIRED (G134=1), GO TO G139 BRANCHPOINT

G136. All in all, would you say that your retirement has turned out to be very satisfying, moderately satisfying, or not at all satisfying?

1. VERY SATISFYING	2. MODERATELY SATISFYING	3. NOT AT ALL SATISFYING	8. DK	9. RF
--------------------	--------------------------	--------------------------	-------	-------

G137. Thinking about your retirement years compared to the years just before you retired, would you say the retirement years have been better, about the same, or not as good?

1. BETTER	3. ABOUT THE SAME	5. NOT AS GOOD	6. RETIRED LESS THAN 1 YEAR AGO.	8. DK	9. RF
-----------	-------------------	----------------	----------------------------------	-------	-------

G138 BRANCHPOINT: IF R WAS COMPLETELY RETIRED AT LAST IW, GO TO G141 BRANCHPOINT

G138. I'm going to read you a list of reasons why some people retire. Please tell me whether, for you, these were very important reasons for retirement, moderately important, somewhat important, or not important at all.

G138a.	1. VERY IMPORTANT	2. MODERATELY IMPORTANT	3. SOMEWHAT IMPORTANT	4. NOT IMPORTANT AT ALL	8. DK	9. RF
Poor health (Was this a very important reason for your retirement, a moderately important reason, somewhat important, or not important at all?)						
Wanted to do other things (Was this a very important reason for your retirement, a moderately important reason, somewhat important, or not important at all?)						
Didn't like the work (Was this a very important reason for your retirement, a moderately important reason, somewhat important, or not important at all?)						
Wanted to spend more time with my family (Was this a very important reason for your retirement, a moderately important reason, somewhat important, or not important at all?)						

G139 BRANCHPOINT: IF THIS IS A REINTERVIEW R, GO TO G141 BRANCHPOINT

G139. Now I'm going to read you a list of things that some people say are good about retirement.

IF R IS COMPLETELY RETIRED (G134=1):

For each one, please tell me if, during your retirement, it has been very important, moderately important, somewhat important, or not important at all.

OTHERWISE:

For each one, please tell me if, for you, they are very important, moderately important, somewhat important, or not important at all.

G139a.	1. VERY IMPORTANT	2. MODERATELY IMPORTANT	3. SOMEWHAT IMPORTANT	4. NOT IMPORTANT AT ALL	8. DK	9. RF
Being your own boss ([Has this been/Is this] very important, moderately important, somewhat important, or not important at all?)						
Being able to take it easy. ([Has this been/Is this]) very important, moderately important, somewhat important, or not important at all?)						
Having the chance to travel. ([Has this been/Is this] very important, moderately important, somewhat important, or not important at all?)						

G140. Now for things that some people say are bad about retirement.

IF R IS COMPLETELY RETIRED (G134=1):

Please tell me if, during your retirement, they have bothered you a lot, somewhat, a little, or not at all.

OTHERWISE:

Please tell me if they worry you a lot, somewhat, a little, or not at all.

NOTE: EACH OF THE THREE WORRIES IN THE TABLE BELOW HAS THE FOLLOWING RETIREMENT CONDITIONS WITH QUESTION FORMS.

IF R IS COMPLETELY RETIRED (G134=1):

Does this bother you a lot, somewhat, a little, or not at all?

IF R IS PARTLY RETIRED (G134=2):

Does this worry you a lot, somewhat, a little, or not at all?

OTHERWISE (G134 {NOT 1 and NOT 2}):

Does this worry you a lot, somewhat, a little, or not at all?

G140a.	1. A LOT	2. SOMEWHAT	3. A LITTLE	4. NOT AT ALL	7. DIDN'T WORK	8. DK	9. RF
1. Not doing anything productive or useful. (Does this [bother/worry] you a lot, somewhat, a little, or not at all?)							
2. Illness or disability. (Does this [bother/worry] you a lot, somewhat, a little, or not at all?)							
3. Not having enough income to get by. (Does this [bother/worry] you a lot, somewhat, a little, or not at all?)							

G141 BRANCHPOINT: IF THIS IS A NEW INTERVIEW R, GO TO G154 (G ASSIST)

IF R IS STILL WORKING FOR LAST IW EMPLOYER (G19b=1), GO TO G145c BRANCHPOINT

IF R WAS WORKING FOR SOMEONE ELSE LAST IW *and* DID NOT GIVE A {MONTH AND YEAR} THAT S/HE STOPPED WORKING FOR THAT EMPLOYER (G26/26a={DK or RF}), GO TO G145c BRANCHPOINT

IF R WAS WORKING FOR SOMEONE ELSE LAST IW *and* STARTED WORKING AT CURRENT JOB/BUSINESS (per G63/G63a) LESS THAN 2 MONTHS FROM WHEN S/HE STOPPED WORKING FOR LAST IW EMPLOYER (per G26/26a), GO TO G145c BRANCHPOINT

IF R WAS SELF-EMPLOYED AT LAST IW *and* DID NOT GIVE {MONTH AND YEAR} THAT S/HE STOPPED WORKING AT THAT BUSINESS (G5/5a={DK or RF}), GO TO G145c BRANCHPOINT

IF R WAS {SELF-EMPLOYED AT LAST IW *and* IS CURRENTLY SELF-EMPLOYED (G2=2)} *and* {MONTH AND YEAR} STARTED WORKING FOR CURRENT BUSINESS (per G63/G63a) IS SAME AS OR BEFORE {MONTH AND YEAR} OF LAST IW, GO TO G145c BRANCHPOINT

IF {MONTH AND YEAR} R STARTED CURRENT JOB/BUSINESS (per G63/G63a) IS ON OR BEFORE {MONTH AND YEAR} OF R's LAST IW, GO TO G145c BRANCHPOINT

IF R WAS SELF-EMPLOYED AT LAST IW *and* {MONTH AND YEAR} R STARTED CURRENT JOB/BUSINESS (per G63/G63a) IS LESS THAN 2 MONTHS FROM {MONTH AND YEAR} S/HE STOPPED WORKING FOR SELF (per G5/5a), GO TO G145c BRANCHPOINT

IF R IS CURRENTLY WORKING (G2=1) *and* DID NOT GIVE {MONTH AND YEAR} S/HE STARTED CURRENT JOB/BUSINESS (per G63/G63a), GO TO G145c BRANCHPOINT

G141. IF R IS CURRENTLY WORKING (G2=1):
 Between [MONTH, YEAR STOPPED WORKING FOR LAST IW [EMPLOYER (per G26&G26a)/SELF (per G5&G5a)]/R's LAST IW MONTH, YEAR] and [MONTH, YEAR STARTED WORKING FOR CURRENT [EMPLOYER)/SELF] (per G63&G63a)] did you do any work for pay?

OTHERWISE:
 Since [MONTH, YEAR STOPPED WORKING FOR LAST IW [EMPLOYER (per G26&G26a)/SELF (per G5&G5a)]/R's LAST IW MONTH, YEAR] did you do any work for pay?

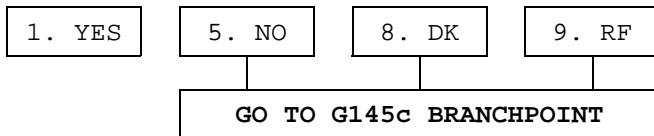

G142. IF R IS CURRENTLY WORKING:

During which months between [MONTH, YEAR STOPPED WORKING FOR LAST IW
[EMPLOYER (per G26&G26a)/SELF (per G5&G5a)]/R's LAST IW MONTH, YEAR]
and

MONTH, YEAR STARTED WORKING FOR {CURRENT EMPLOYER OR SELF} (per
G63&G63a) did you work for pay?

OTHERWISE:

During which months since [MONTH, YEAR STOPPED WORKING FOR LAST IW
[EMPLOYER (per G26&G26a)/SELF (per G5&G5a)]/R's LAST IW MONTH, YEAR]
did you work for pay?

[IWER: CHOOSE ALL THAT APPLY]

01. JAN 98	02. FEB 98	03. MAR 98	04. APR 98	05. MAY 98	06. JUN 98	07. JUL 98
08. AUG 98	09. SEP 98	10. OCT 98	11. NOV 98	12. DEC 98	13. JAN 99	14. FEB 99
15. MAR 99	16. APR 99	17. MAY 99	18. JUN 99	19. JUL 99	20. AUG 99	21. SEP 99
22. OCT 99	23. NOV 99	24. DEC 99	25. JAN 00	26. FEB 00	27. MAR 00	28. APR 00
29. MAY 00	30. JUN 00	31. JUL 00	32. AUG 00	33. SEP 00	34. OCT 00	35. NOV 00
36. DEC 00	37. JAN 01	38. FEB 01	39. MAR 01	40. ALL OF 1998 (AFTER PREV IW IN HH'S LAST IW MONTH)		41. ALL OF 1999
42. ALL OF 1999 (AFTER PREV IW IN HH'S LAST IW MONTH)		43. ALL OF 2000 TO DATE		44. ALL OF 1992 (AFTER PREV IW IN HH'S LAST IW MONTH)		45. ALL OF 1993
46. ALL OF 1993 (AFTER PREV IW IN HH'S LAST IW MONTH)		47. ALL OF 1994		48. ALL OF 1994 (AFTER PREV IW IN HH'S LAST IW MONTH)		49. ALL OF 1995
50. ALL OF 1995 (AFTER PREV IW IN HH'S LAST IW MONTH)		51. ALL OF 1996		52. ALL OF 1996 (AFTER PREV IW IN HH'S LAST IW MONTH)		53. ALL OF 1997
54. ALL OF 1997 (AFTER PREV IW IN HH'S LAST IW MONTH)		55. ALL OF 1998		97. OTHER (SPECIFY) _____		98. DK
						99. RF

NOTE: THE ONLY CHOICES PRESENTED TO THE IWER ARE THOSE FOR MONTHS AND/OR
YEARS FROM R'S LAST IW DATE UNTIL CURRENT IW MONTH & YEAR.

G143. During these months, how many hours per week did you usually work?

_____ HOURS

DK	RF
----	----

G144. On average, how much were you earning before deductions during these months?

[IWER: IF PER HOUR BE SURE TO ADD .00 FOR CENTS IF THERE ARE NONE]

[IWER: PROBE IF NECESSARY]

Was that per hour, week, month, or year?

AMOUNT

DK	RF
----	----

GO TO G144b

G144a. PER:

01. HOUR	02. WEEK	03. EVERY TWO WEEKS/BI-WEEKLY	04. MONTH
06. YEAR	97. OTHER (SPECIFY) _____	98. DK	99. RF

G144b. Counting yourself as an employer if you were self employed, for how many employers did you work during those months?

1. ONE	2. TWO OR MORE	8. DK	9. RF
--------	----------------	-------	-------

GO TO G145c BRANCHPOINT

G145. Why did you stop working at that job? (Did the business close, were you laid off or let go, did you leave to take care of family members or what?)

[IWER: CHOOSE ALL THAT APPLY]

01. BUSINESS CLOSED	02. LAID OFF/LET GO	03. POOR HEALTH/DISABLED	04. FAMILY CARE	05. BETTER JOB
---------------------	---------------------	--------------------------	-----------------	----------------

GO TO G145c BRANCHPOINT

06. QUIT	07. RETIRED	97. OTHER (SPECIFY) _____	98. DK	99. RF
----------	-------------	------------------------------	--------	--------

G145a. Did your employment situation change in some way that encouraged you to leave?

1. YES	5. NO	8. DK	9. RF
GO TO G145c BRANCHPOINT			

G145b. How did it change?

[IWER: CHOOSE ALL THAT APPLY]

01. SUPERVISOR ENCOURAGED DEPARTURE	02. COWORKER ENCOURAGED DEPARTURE	03. WAGES REDUCED (OR ABOUT TO BE REDUCED)	04. HOURS REDUCED (OR ABOUT TO BE REDUCED)
05. WOULD HAVE BEEN LAID OFF	06. NEW JOB DUTIES	07. NEW JOB LOCATION	08. BECAME ELIGIBLE FOR PENSION
09. EMPLOYER CHANGED HEALTH INSURANCE	10. SPECIAL EARLY RETIREMENT INCENTIVE OFFER	97. OTHER (SPECIFY) _____	98. DK
			99. RF

G145c BRANCHPOINT: IF R DID NOT REPORT THAT IS CURRENTLY WORKING FOR PAY (G2={5 or DK or RF}) and DID NOT REPORT AT R's LAST IW THAT WAS WORKING FOR PAY and DID NOT REPORT THAT HAS WORKED FOR PAY BETWEEN {LEAVING LAST IW EMPLOYER AND {THE PRESENT OR START OF CURRENT EMPLOYMENT}} (G141={5 or DK or RF}), GO TO G154 (G ASSIST)

G145c. Counting paid vacations as weeks of work, how many weeks did you work in the last 12 months?

[IWER: COUNT PAID SICK TIME AS WORK TIME]

DK	RF
----	----

WEEKS

G146 BRANCHPOINT: IF R IS SELF-EMPLOYED NOW (G3=2) and WAS SELF-EMPLOYED AT R's LAST IW, GO TO G154 (G ASSIST)

IF R WAS SELF-EMPLOYED AT R's LAST IW and DID NOT REPORT THAT IS WORKING FOR PAY NOW (G2 NOT 1) and DID NOT REPORT THAT HAS WORKED FOR PAY BETWEEN {LAST IW AND START OF CURRENT EMPLOYMENT} (G141={5 or DK or RF}), GO TO G154 (G ASSIST)

IF R DID NOT REPORT AT R's LAST IW THAT WAS WORKING FOR PAY and IS SELF-EMPLOYED NOW (G3=2) and DID NOT REPORT THAT HAS WORKED FOR PAY BETWEEN {LAST IW AND START OF CURRENT EMPLOYMENT} (G141={5 or DK or RF}), GO TO G154 (G ASSIST)

G146. Employers sometimes encourage older workers to leave a firm at a particular time by offering a special financial incentive, like a cash bonus or improved pension benefits. These are often called "early retirement windows."

Have you been offered such an early retirement window at any time since R's LAST IW MONTH, YEAR?

1. YES	5. NO	8. DK	9. RF
GO TO G154 (G ASSIST)			

G146a. How many of these special incentive offers have you received [since R's LAST IW MONTH, YEAR/in the last two years]?

SPECIAL INCENTIVES

DK	RF
GO TO G154 (G ASSIST)	

BEGINNING OF G147a LOOP: QUESTIONS G147a THROUGH G153 ARE REPEATED FOR THE FIRST AND LAST SPECIAL INCENTIVES THE R RECEIVED.

G147a. In what month and year was the (first/last) special incentive offered?

[IWER: MONTHS ENTERED MUST BETWEEN [NOVEMBER, YEAR 2 YEARS AGO/ REINTERVIEW R's LAST IW MONTH, YEAR] AND CURRENT LAST IW MONTH, YEAR]

G147a. MONTH:

01. JAN	02. FEB	03. MAR	04. APR	05. MAY	06. JUN	07. JUL
08. AUG	09. SEP	10. OCT	11. NOV	12. DEC	98. DK	99. RF

DK	RF
----	----

G147b. YEAR

G148 BRANCHPOINT: IF R IS STILL WORKING FOR LAST IW EMPLOYER (G19b=1), GO TO G149

G148. Which employer were you working for at the time?

[IWER: ENTER FULL EMPLOYER NAME:]

1. LAST WAVE EMPLOYER NAME	2. CURRENT EMPLOYER NAME	7. OTHER (SPECIFY) _____	8. DK	9. RF
-------------------------------	-----------------------------	-----------------------------	-------	-------

G149. Was the special incentive a cash bonus, improved pension benefits or what?

[IWER: CHOOSE ALL THAT APPLY]

1. CASH BONUS	2. IMPROVED PENSION BENEFITS	3. PERMANENT MEDICAL INSURANCE	4. TEMPORARY MEDICAL INSURANCE	
5. TEMPORARY CASH BENEFIT	6. ADDITIONAL YEARS OF SERVICE CREDITED	7. OTHER (SPECIFY) _____	8. DK	9. RF

G150a BRANCHPOINT: IF R's OFFER DID NOT INCLUDE A CASH BONUS (G149 NOT 1),
GO TO G150b BRANCHPOINT

G150a. How much did the cash bonus offer amount to?

AMOUNT

DK	RF
----	----

G150b BRANCHPOINT: IF R's OFFER DID NOT INCLUDE IMPROVED PENSION BENEFIT
(G149 NOT 2), GO TO G150c BRANCHPOINT

G150b. How much did the extra pension benefit offer amount to?

[IWER: IF PER HOUR BE SURE TO ADD .00 FOR CENTS IF THERE ARE NONE]

[IWER: PROBE IF NECESSARY]

Was that per week, year, or a lump sum?

AMOUNT

DK	RF
GO TO G105c BRANCHPOINT	

G150Y1b. PER:

02. WEEK	04. MONTH	06. YEAR	95. LUMP SUM
97. OTHER (SPECIFY) _____	98. DK	99. RF	

G150c BRANCHPOINT: IF R's OFFER DID NOT INCLUDE TEMPORARY MEDICAL INSURANCE (G149 NOT 4), GO TO G150d BRANCHPOINT

G150c. Until what age was the temporary medical insurance offered?

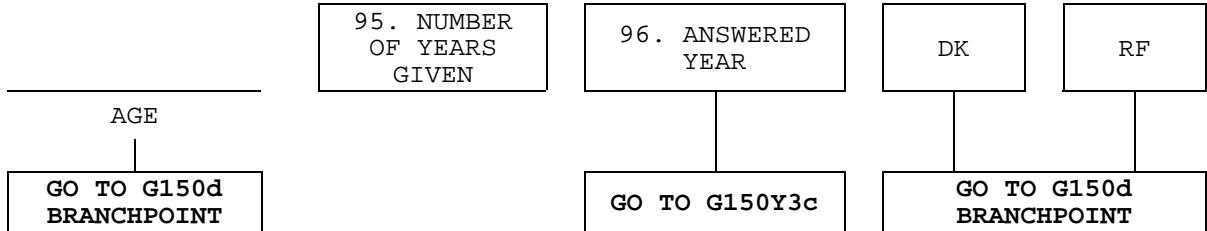

G150Y2c. [IWER: PROBE IF NECESSARY]

For how many years was the temporary medical insurance offered?

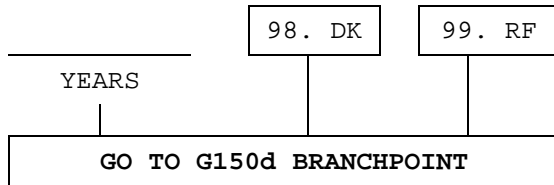

G150Y3c. [IWER: PROBE IF NECESSARY]

Until which year did you receive the temporary medical insurance?



G150d BRANCHPOINT: IF R's OFFER DID NOT INCLUDE TEMPORARY CASH BENEFITS (G149 NOT 5), GO TO G150g BRANCHPOINT

G150d. How much did the temporary cash benefits offer amount to?

[IWER: PROBE IF NECESSARY]
Was that per month or year?

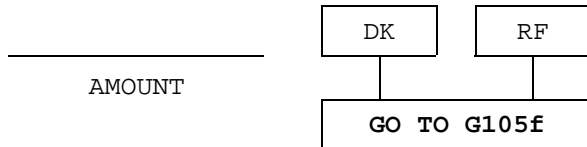

G150e. PER:

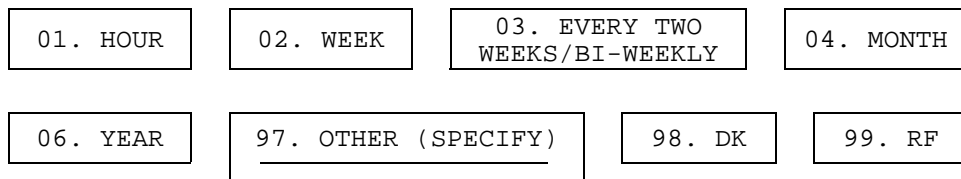

G150f. Until what age was the temporary cash benefit offered?

_____	95. NUMBER OF YEARS GIVEN	96. ANSWERED YEAR	DK	RF
AGE				
GO TO G150g BRANCHPOINT		GO TO G150Y5f	GO TO G150g BRANCHPOINT	

G150Y4f. [IWER: PROBE IF NECESSARY]

For how many years was the temporary cash benefit offered?

_____	DK	RF
YEARS		
GO TO G150g BRANCHPOINT		

G150Y5f. [IWER: PROBE IF NECESSARY]

Until which year was the temporary cash benefit offered?

_____	DK	RF
YEAR		

G150g BRANCHPOINT: IF R's OFFER DID NOT INCLUDE ADDITIONAL YEARS OF SERVICE CREDIT (G149 NOT 6), GO TO G150h BRANCHPOINT

G150g. How many years of service credit were you offered?

_____	DK	RF
YEARS		

G150h BRANCHPOINT: IF R's OFFER DID NOT INCLUDE OTHER INCENTIVES (G149 NOT 7), GO TO G151

G150h. How much did the other incentive offers(s) amount to?

_____	DK	RF
AMOUNT		

G151. Did you accept the incentive and leave that employer?

1. YES	5. NO	8. DK	9. RF
GO TO G153			

G152. Was the special incentive important in your decision, or would you probably have left at about that time anyway?

1. IMPORTANT IN MY DECISION	5. I WOULD HAVE LEFT ANYWAY	8. DK	9. RF
GO TO END OF LOOP (AFTER G153)			

G153. If you had been offered twice as much (to leave) at that time, would you have done so?

1. YES	5. NO	8. DK	9. RF
--------	-------	-------	-------

****END OF G147a LOOP: REPEAT QUESTIONS G147a THROUGH G153 IF MORE THAN ONE EARLY OUT WINDOW WAS OFFERED. IF NOT, CONTINUE ON TO G154 (G ASSIST).****

G154. G ASSIST

IWER: HOW OFTEN DID R RECEIVE ASSISTANCE WITH ANSWERS IN SECTION G — WORK?

1. NEVER	2. A FEW TIMES	3. MOST OR ALL OF THE TIME	4. THE SECTION WAS DONE BY A PROXY REPORTER
----------	----------------	-------------------------------	--

GO TO SECTION GG